

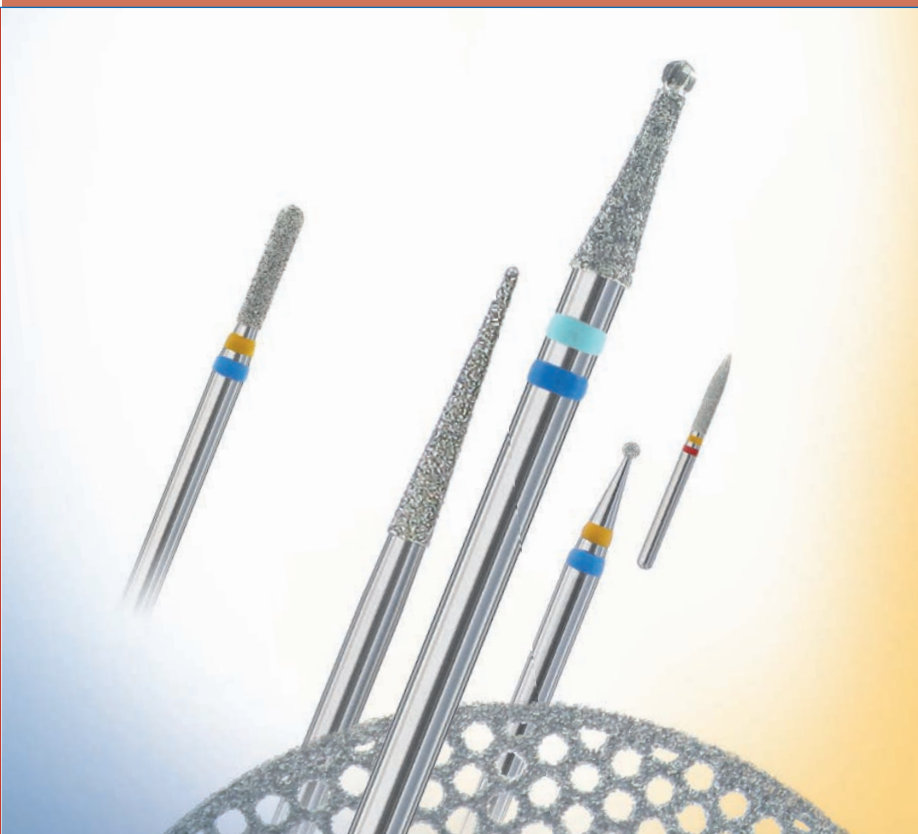

SW/SSdental



DIAMANT-SCHLEIFINSTRUMENTE DIAMOND INSTRUMENTS

Zahnarztpraxis
Dental clinic



Dental Labor
Dental laboratory



sw/ssdental

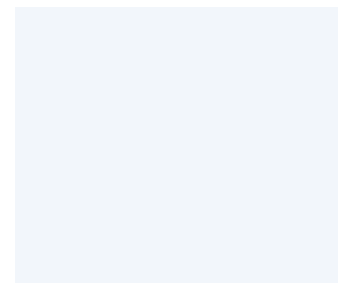
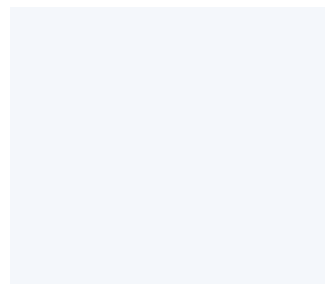
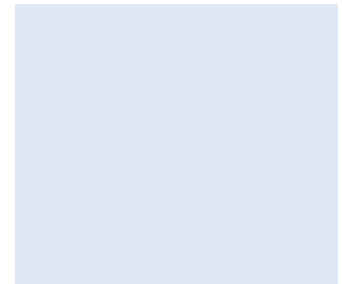
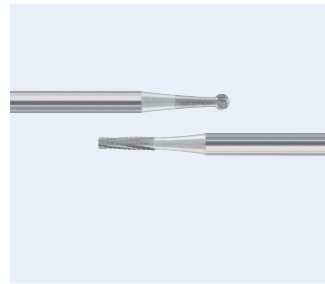
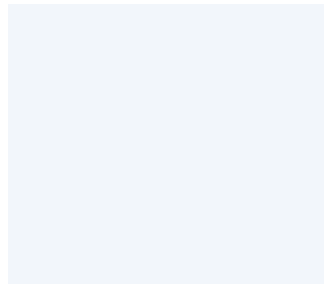
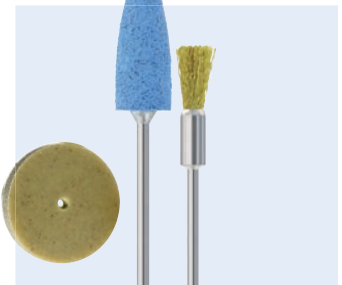
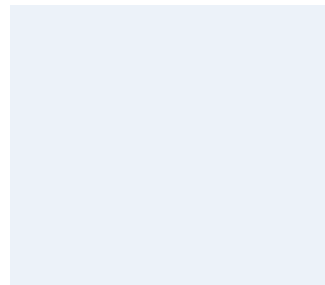
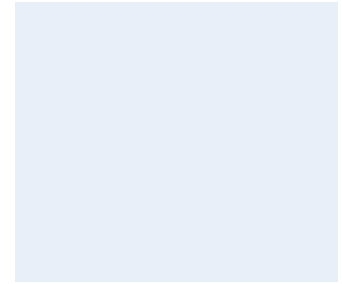



UNSER PRODUKTPROGRAMM OUR RANGE OF PRODUCTS

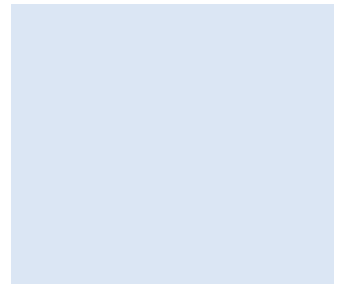
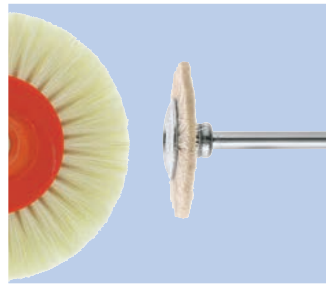
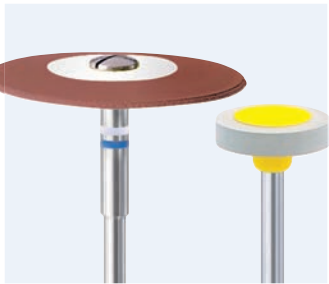
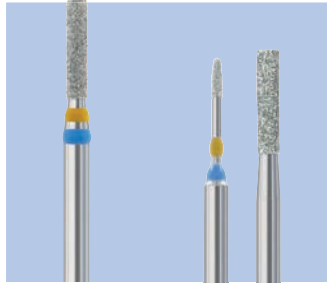
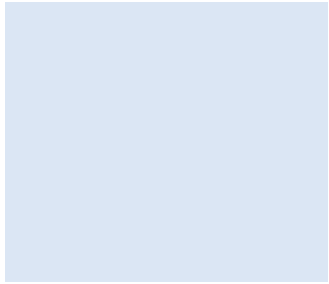
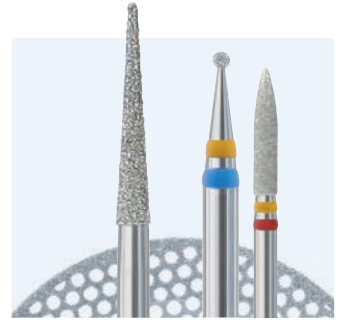
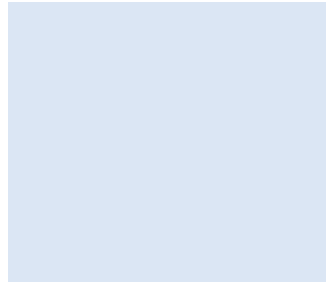
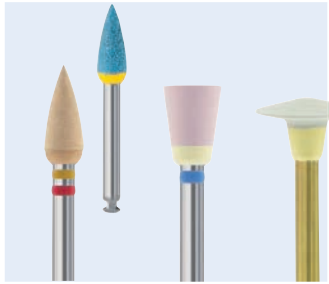

QUALITÄT

Entwicklung, Fertigung und Vertrieb im Rahmen eines zertifizierten Qualitätsmanagementsystems nach dem internationalen Standard EN ISO 13485. Die Medizinprodukte erfüllen zusätzlich die Anforderungen nach Anhang II (Abschnitt 3) der Richtlinie 93/42/EWG und sind CE-zertifiziert.

Alle Vorgänge entsprechen den Qualitätsrichtlinien der Unternehmensleitung, welche die Einhaltung des Qualitätsmanagement seit 2003 nach EN ISO 13485 fordert.

QUALITY

Development, manufacturing and distribution in the framework of certified quality management system in compliance with the international standard EN ISO 13485. The medical devices meets the relevant requirements of annex II (section 3) of the directive 93/42/EEC and are CE-certified.

All process fit the quality rules of our management, which requires compliance with quality management system EN ISO 13485.

ZERTIFIKATE · AKKREDITIERUNGEN

Wir sind Mitglied im „European Health Industry Business Communication Council“ sowie in einzelnen Ländern durch eine entsprechende Akkreditierung zum Import von medizinischen Gütern berechtigt.

Die aktuellen Zertifikate sowie weitere Informationen finden Sie unter www.swissdental.net

CERTIFICATES · ACCREDITATIONS

We are member of the “European Health Industry Business Communication Council“ as well as through corresponding accreditations in some countries allowed to export medical goods without restrictions.

Further details and our latest certificates are published on www.swissdental.net

FORSCHUNG · ENTWICKLUNG

Die Firma entwickelt eigene Produkte und Dienstleistungen in Zusammenarbeit mit professionellen, nationalen und internationalen Endverbrauchern, Meinungsbildnern sowie Institutionen.

RESEARCH · DEVELOPMENT

Our products and services were produced by our own in a close relationship with professional, national and international clients, opinion leaders and organisations.

PRODUKTIONSTÄTIGKEIT

Die Herstellung der Produkte wird in der Regel an externe Produktionsunternehmen übertragen.

PRODUCTIVE ACTIVITIES

We generally outsource our manufacturing jobs to an external party.

VERTRIEB

Der Verkauf der eigenen Produkte findet über den Fachhandel statt.

MARKETING · SALES

You are finding our products at your speciality retailer.

DIAMANT- SCHLEIFINSTRUMENTE für Zahnarztpraxis und Dental Labor

INHALT

- Diamant-Schleifer

WERKSTOFF DES ARBEITSTEILS

- Diamantkorn

METALLBINDUNG

- galvanisch

KORNART

- Natur/synthetisch

ISO-NUMMER

- 806

DIAMOND INSTRUMENTS

for dental clinic and dental laboratory

CONTENT

- Diamond instruments

MATERIAL OF THE WORKINGPART

- Diamond grit

METAL BOND

- galvanic

GRAIN TYPE

- natural/synthetic

ISO NUMBER

- 806

BESTELLBEISPIEL ORDER EXAMPLE

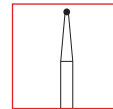









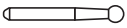

Strichzeichnungen 1:1
Line drawings 1:1

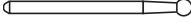
Form Shape ISO form ISO shape	801 001	Ø mm	0,7	0,8	0,9	1,0	Durchmesser Diameter
		L mm	-	-	-	-	Länge Length
		Angle α	-	-	-	-	Winkel Angle
		105-125 µm	801	801	801	801	
		180 µm					
		150 µm			801G	801G	
		40 µm		801F	801F	801F	
		20 µm		801EF		801EF	
		15 µm					
		FG	314	314	314	314	
		FGS			313	313	
		ISO Ø	007	008	009	010	
		Form & Körnung Shape & Grit size:			801		
		Schaft Shank:			313		
		Durchmesser Diameter:			009		
		Bestellnummer Order number:			801.313.009		

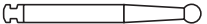
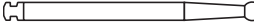
KOPFDURCHMESSER
HEAD DIAMETER

ISO Ø	Ø mm
007	0,7
008	0,8
009	0,9
010	1,0
012	1,2
014	1,4
016	1,6
018	1,8
021	2,1
023	2,3
025	2,5
027	2,7
029	2,9
031	3,1
033	3,3
035	3,5
037	3,7
040	4,0
042	4,2
045	4,5
047	4,7
050	5,0
055	5,5
060	6,0
065	6,5
070	7,0
075	7,5
080	8,0







SCHAFT-ARTEN
KIND OF SHANKS













Arten Types	Beschreibung Description	Ø mm Ø mm	Länge mm Length mm	ISO Nummer ISO number
FGS FGS	FG kurz Friction Grip short  Standard grit only	1,60	16,00	313
FG FG	FG Friction Grip 	1,60	19,00	314
FGL FGL	FG lang Friction Grip long 	1,60	21,00	315
FGXL FGXL	FG extra lang Friction Grip extra long 	1,60	25,00	316
W RA	Winkel Right-angle  Standard grit only	2,35	22,00	204
WL RAL	Winkel lang Right-angle long 	2,35	26,00	205
WXL RAXL	Winkel extra lang Right-angle extra long 	2,35	34,00	206
HS HPS	Handstück kurz Handpiece short 	2,35	34,00	103
H HP	Handstück Standard Handpiece standard 	2,35	44,50	104
HL HPL	Handstück lang Handpiece long 	2,35	65,00	105
HXL HPXL	Handstück extra lang Handpiece extra long 	2,35	70,00	106
HST HPST	Handstück Industrie kurz Handpiece industry short 	3,00	34,00	123
HT HPT	Handstück Industrie Handpiece industry 	3,00	44,50	124

Strichzeichnungen 1:1 (konstruktionsbedingte Längenabweichungen vorbehalten)
Line drawings 1:1 (constructional length differences reserved)

FARBCODIERUNG COLOUR CODING

Werkstoff
Material

	Metall Metal
	Edelmetall Precious metal
	Keramik Ceramic
	Zirkonoxid Zirconia
	Dentalkunststoff Dental plastic
	Zahn- und Knochensubstanz Tooth and bone substance

Körnung Grit	 Korngrösse Grit size	 Korngrösse Grit size	ISO Nummer ISO number
Mittel medium	 105-125 µm	 110-120 µm	524
Supergrob (SG) Super coarse	 180 µm	 180 µm	544
Grob (G) Coarse	 150 µm	 150 µm	534
Fein (F) Fine	 40 µm	 40 µm	514
Extrafein (EF) Extra fine	 20 µm		504
Ultrafein (UF) Ultra fine	 15 µm		494



PRODUKTETIKETT PRODUCT LABEL

Folgende genormte Daten werden verwendet:

- CE-Zeichen (Medizinprodukte)
- Hersteller/Marke
- Anwendungssymbole
- Bestell-/Referenznummer (REF)
- Artikelbeschreibung
- LOT Nummer (Rückverfolgbarkeit)
- ISO Nummer
- Produktabbildung
- Max. zulässige Umdrehungszahl
- Empfohlene Umdrehungszahl
- Verpackungseinheit
- Ablaufdatum
- Kontaktdaten
- HIBC (Barcode/Klarschrift)
- Matchcode
- ISO Farbstreifen
- ISO Herstellungsdatum
- Gebrauchsanweisung/Katalog beachten

The following standardized symbols are used:

- CE-marking for medical products
- The manufacturer/brand
- Application symbols
- Order-/Reference number (REF)
- Article description
- LOT number (traceability)
- ISO number
- Product drawing
- Max. permitted speed
- Rec. operational speed
- Packing unit
- Expiry date
- Contact details
- HIBC (barcode/plain text)
- Matchcode
- ISO colour coding
- ISO date of manufacture
- Consult instructions/catalogue

PIKTOGRAMME ICONS

- | | | |
|--|--|--|
|  Zahnarztpraxis
Dental clinic |  Abgerundete Kanten
Rounded edges |  Kronentrennen
Crown cutting |
|  Dental Labor
Dental laboratory |  Füllungsbearbeitung
Working on fillings |  Kronen- und Brückentechnik
Crown and bridge technique |
|  Länge des Arbeitsteils
Length of the working part |  Implantologie
Implantology |  Kunststofftechnik
Acrylic technique |
|  Schnitttiefe
Cutting depth |  Kavitätenpräparation
Cavity preparation |  Modellherstellung
Model fabrication |
|  Verpackungseinheit
Packing unit |  Kieferchirurgie
Jaw surgery |  Wurzelglättung
Root smoothening |
| |  Kronenpräparation
Crown preparation |  Wurzelkanalaufbereitung
Root canal treatment |

UMDREHUNGSZAHLEN: FG und FG kurz
SPEEDS: FG and FG short

Körnung Grit size	■	○ max. Max. Drehzahl Max. permitted speed min ⁻¹	Werkstoff Material	■	○ rec. Empf. Drehzahl Recommended speed min ⁻¹
	■			■	
	■			■	
	■			■	
	■			■	





























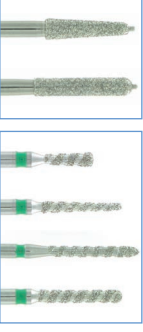

ISO Ø 1/10mm			
007 – 010	450'000		75'000 – 150'000
012 – 014	450'000		60'000 – 110'000
016 – 018	450'000		45'000 – 90'000
021 – 023	300'000		40'000 – 75'000
025 – 027	160'000		30'000 – 65'000
029 – 031	140'000		25'000 – 55'000
033 – 040	120'000		22'000 – 45'000
042 – 050	95'000		15'000 – 35'000
055 – 070	60'000		12'000 – 25'000
080 – 100	45'000		10'000 – 20'000
120 – 140	35'000		8'000 – 15'000
160 – 180	27'000		6'000 – 12'000
200 – 220	27'000		5'000 – 11'000

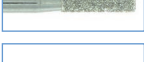
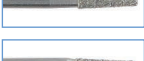
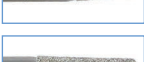
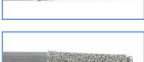
UMDREHUNGSZAHLEN: H
SPEEDS: HP

Körnung Grit size	■	○ max. Max. Drehzahl Max. permitted speed min ⁻¹	Werkstoff Material	■	○ rec. Empf. Drehzahl Recommended speed min ⁻¹	□	○ rec. Empf. Drehzahl Recommended speed min ⁻¹
	■			■		□	
	■			■		□	
	■			■		□	
	■			■		□	

ISO Ø 1/10mm		Metalle	Nichtmetalle
007 – 010	45'000	10'000 – 32'000	15'000 – 35'000
012 – 014	45'000	10'000 – 32'000	15'000 – 35'000
016 – 018	45'000	10'000 – 32'000	15'000 – 35'000
021 – 023	45'000	10'000 – 32'000	15'000 – 35'000
025 – 027	45'000	10'000 – 32'000	15'000 – 35'000
029 – 031	45'000	10'000 – 32'000	15'000 – 35'000
033 – 040	45'000	8'000 – 28'000	15'000 – 35'000
042 – 050	45'000	8'000 – 28'000	15'000 – 30'000
055 – 070	30'000	8'000 – 28'000	15'000 – 30'000
080 – 100	30'000	8'000 – 28'000	10'000 – 20'000
120 – 140	30'000	8'000 – 28'000	10'000 – 20'000
160 – 180	25'000	8'000 – 28'000	10'000 – 20'000
200 – 220	20'000	8'000 – 28'000	10'000 – 20'000



Seite Page	Präparations-Instrumente Preparation instruments	Seite Page	Präparations-Instrumente Preparation instruments
8 – 9	 Rund Round	33	 Granate Grenade
10	 Umgekehrter Kegel Inverted cone	32	 Knospe Bud
11	 Diabolo Diabolo	32	 Ei Egg/Football
12 – 13 33	 Birne Pear	33	 Interdental Interproximal
13	 Doppelkegel Double cone	33	 Kavitätenrandabschräger Cavity margin trimmer
15	 Okklusal-/Palatinalschleifer Occlusal-/palatal grinder	33 – 34	 Kürettage Curettage
14 – 15	 Rad Wheel	36 – 38	 In-/On-/Overlay In-/On-/Overlay
16	 Linse Lenticular	35	 Veneertechnik Veneer technique
16	 Tiefenmarkierer Depth marker	39	 Instrumente mit Führungsschaft Guide-pin-diamonds
17 – 18	 Zylinder Cylinder	40 – 41	 Speedies Speedies
19 – 21	 Zylinder rund Cylinder round		
30 – 31	 Zylinder spitz Cylinder pointed		
19	 Zylinder Stirn belegt Cylinder end-coated only		
36 – 37	 Zylinder mit abgerundeter Kante Cylinder with rounded edge		
21 – 23	 Konisch Tapered		
23 – 24	 Konisch rund Tapered round		
24 – 25 44	 Konisch rund, lang Tapered round, long		
35	 Konisch mit nicht schneidender Spitze Tapered with safe end		
37 – 38	 Konisch mit abgerundeter Kante Tapered with rounded edge		
25 – 27	 Konisch spitz Tapered pointed		
27 – 29	 Flamme Flame		
28 – 30	 Torpedo Torpedo		
33 – 34	 Torpedo konisch Torpedo tapered		
31	 Nadel Needle		
		Seite Page	Mikropräparations-Instrumente Micropreparation instruments
		42	



Zahnarztpraxis Dental clinic

Seite Page	Perio-Instrumente Perio instruments
43	
Seite Page	Chirurgie-/Implantologie-Instrumente Oral surgery/Implantology instruments
44 – 45	
Seite Page	ZrO ₂ Bearbeitung ZiRoDia ZrO ₂ processing ZiRoDia
46 – 47	



801
001



Ø mm	0,8	0,9	1,0	1,2	1,4	1,6	1,8	2,0	2,1
L mm	-	-	-	-	-	-	-	-	-
105-125 µm	801	801	801	801	801	801	801	801	801
180 µm				801SG	801SG	801SG	801SG	801SG	801SG
150 µm				801G	801G	801G	801G	801G	801G
40 µm	801F	801F	801F	801F	801F	801F	801F	801F	801F
20 µm				801EF	801EF	801EF	801EF	801EF	801EF
FG	314	314	314	314	314	314	314	314	314
FGS			313	313	313	313	313		
W RA			204	204	204	204	204		
ISO Ø	008	009	010	012	014	016	018	020	021

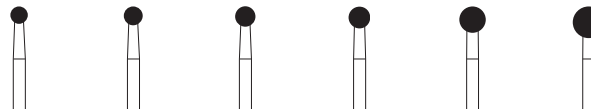

801
001



Ø mm	2,3	2,5	2,7	2,9	3,5	4,2
L mm	-	-	-	-	-	-
105-125 µm	801	801	801	801	801	801
150-180 µm	801SG	801SG	801SG	801SG	801SG	
125-150 µm	801G	801G	801G	801G	801G	801G
45 µm	801F	801F	801F	801F	801F	
15 µm	801EF	801EF	801EF	801EF	801EF	
FG	314	314	314	314	314	314
W RA	204			204		
ISO Ø	023	025	027	029	035	042

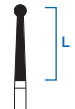

802LE
002



L mm	1,4
	10,0
	802LE
	802LE-G
	315**
	014

** ⌀ max.: 300'000 / rec.: 70'000 – 140'000



801L

697



Ø mm	1,0	1,2	1,4	1,6	1,8	2,3	2,9
L mm	-	-	-	-	-	-	-
105-125 µm	801L	801L	801L	801L	801L	801L	801L
150-180 µm	801L-SG				801L-SG	801L-SG	801L-SG
125-150 µm	801L-G	801L-G	801L-G	801L-G	801L-G	801L-G	801L-G
45 µm							
15 µm							
FGL	315**	315**	315**	315**	315*	315*	315*
ISO Ø	010	012	014	016	018	023	029



802

002



Ø mm	0,8	0,9	1,0	1,2	1,4	1,6	1,8	2,1	2,3
L mm	2,5	2,5	2,5	3,0	3,0	3,0	3,5	4,0	4,5
105-125 µm	802	802	802	802	802	802	802	802	802
150-180 µm				802SG	802SG	802SG	802SG	802SG	802SG
125-150 µm				802G	802G	802G	802G	802G	802G
45 µm	802F	802F	802F	802F	802F	802F	802F	802F	802F
15 µm									
FG	314	314	314	314	314	314	314	314	314
FGS				313		313			313
ISO Ø	008	009	010	012	014	016	018	021	023

* ○ max.: 140'000 / rec.: 30'000 – 60'000

** ○ max.: 300'000 / rec.: 70'000 – 140'000



805
010



Ø mm	0,9	1,0	1,2	1,4	1,6	1,8	2,1	2,3
L mm	1,0	1,0	1,2	1,4	1,4	1,6	2,1	2,1
105-125 µm	805	805	805	805	805	805	805	805
180 µm				805SG	805SG	805SG	805SG	805SG
150 µm			805G	805G	805G	805G	805G	805G
40 µm								
20 µm								
FG	314	314	314	314	314	314	314	314
FGS		313	313		313			
W RA		204	204	204	204		204	
ISO Ø	009	010	012	014	016	018	021	023

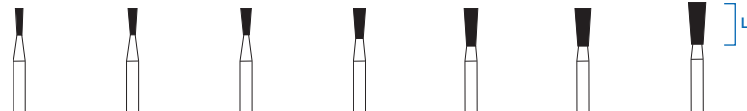

807
225



Ø mm	1,0	1,2	1,4	1,6	1,8	2,1	2,3
L mm	3,5	3,5	3,5	4,0	5,0	5,0	6,0
105-125 µm	807	807	807	807	807	807	807
180 µm				807SG			
150 µm		807G	807G	807G	807G		
40 µm							
20 µm							
FG	314	314	314	314	314	314	314
ISO Ø	010	012	014	016	018	021	023



806

019



Ø mm	0,9	1,0	1,2	1,4	1,6	1,8	2,3
L mm	2,2	2,2	3,0	3,5	3,5	3,5	4,0
105-125 µm	806	806	806	806	806	806	806
180 µm				806SG	806SG	806SG	806SG
150 µm			806G	806G	806G	806G	806G
40 µm							
20 µm							
FG	314	314	314	314	314	314	314
FGS		313	313				
ISO Ø	009	010	012	014	016	018	023



813

032



Ø mm	1,0	1,4	1,6	1,8
L mm	1,5	1,5	2,0	2,0
105-125 µm	813	813	813	813
180 µm				813SG
150 µm		813G	813G	
40 µm				
20 µm				
FG	314	314	314	314
ISO Ø	010	014	016	018



L

830 233	Ø mm	0,8	0,9	1,0	1,2	1,4	1,6
	L mm	2,5	2,7	2,7	2,7	2,7	2,7
	105-125 µm	830	830	830	830	830	830
	180 µm				830SG	830SG	830SG
	150 µm			830G	830G	830G	830G
	40 µm			830F	830F	830F	
	20 µm				830EF		
	FG	314	314	314	314	314	314
	ISO Ø	008	009	010	012	014	016

Kavitätenpräparation
Cavity preparation



L

830L 234	Ø mm	1,0	1,2	1,4	1,6	1,8
	L mm	4,0	4,0	5,0	5,0	5,0
	105-125 µm	830L	830L	830L	830L	830L
	180 µm			830L-SG	830L-SG	830L-SG
	150 µm		830L-G	830L-G	830L-G	830L-G
	40 µm	830L-F	830L-F	830L-F	830L-F	
	20 µm	830L-EF		830L-EF		
	FG	314	314	314	314	314
	ISO Ø	010	012	014	016	018



830RL

238



Ø mm	1,2	1,4	1,6	1,8
L mm	4,0	5,0	5,0	5,0
■ 105-125 µm	830RL	830RL	830RL	830RL
■ 180 µm		830RL-SG	830RL-SG	830RL-SG
■ 150 µm	830RL-G	830RL-G	830RL-G	830RL-G
■ 40 µm	830RL-F		830RL-F	
■ 20 µm				
FG	314	314	314	314
ISO Ø	012	014	016	018



811

038



Ø mm	3,1	3,3	3,7	4,8
L mm	4,2	5,0	7,0	8,0
■ 105-125 µm	811	811	811	811
■ 180 µm	811SG	811SG	811SG	811SG
■ 150 µm	811G	811G	811G	811G
■ 40 µm				
■ 20 µm				
FG	314	314	314	314
ISO Ø	031	033	037	048

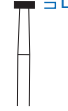

815		Ø mm	1,2	1,6	1,8	2,3	2,7
042		L mm	0,5	0,7	0,7	0,8	1,0
	105-125 µm	815	815	815	815	815	815
	180 µm						
	150 µm			815G	815G	815G	815G
	40 µm						
	20 µm						
	FG	314	314	314	314	314	314
	ISO Ø	012	016	018	023	027	



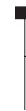

818		Ø mm	3,5	4,0	5,0
041		L mm	0,7	0,7	0,7
	105-125 µm	818	818	818	818
	180 µm				
	150 µm		818G	818G	
	40 µm				
	20 µm				
	FG	314	314	314	
	ISO Ø	035	040	050	





820		Ø mm	4,2
042		L mm	1,5
	105-125 µm	820	820
	180 µm		
	150 µm		
	40 µm		
	20 µm		
	FG	314	
	ISO Ø	042	



899 033   	Ø mm	2,1	2,7	3,1
	L mm	6,5	7,0	7,0
	105-125 µm	899	899	899
	180 µm	899SG	899SG	899SG
	150 µm	899G	899G	899G
	40 µm	899F	899F	
	20 µm			
	FG	314	314	314
	ISO Ø	021	027	031



909 068   	Ø mm	4,0	4,5	5,5
	L mm	1,5	1,5	2,0
	105-125 µm	909	909	909
	180 µm	909SG	909SG	909SG
	150 µm	909G	909G	909G
	40 µm	909F		909F
	20 µm			
	FG	314	314	314
	ISO Ø	040	045	055

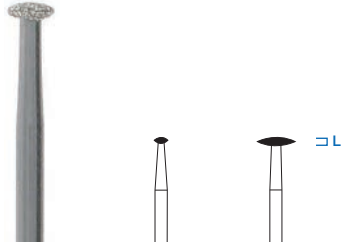

825	Ø mm	1,8	5,0
	L mm	0,8	1,5
304			
	105-125 µm	825	825
	180 µm		
	150 µm		
	40 µm		
	20 µm		
	FG	314	314
	ISO Ø	018	050

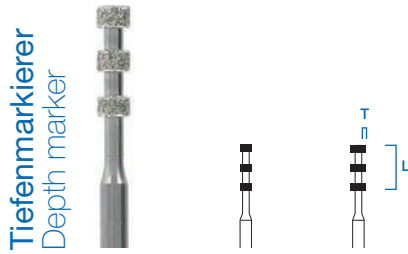

834	Ø mm	1,6	2,1
	L mm	6,8	6,8
552	T mm	0,3	0,5
	105-125 µm	834	834
	180 µm		
	150 µm		
	40 µm		
	20 µm		
	FG	314*	314*
	ISO Ø	016	021

* ⌀ max.: 140'000 / rec.: 30'000 – 60'000



835

107



Ø mm	0,7	0,8	0,9	1,0	1,2	1,4	1,6	1,8
L mm	3,0	3,0	3,0	4,0	4,0	4,0	4,0	4,0
105-125 µm	835	835	835	835	835	835	835	835
180 µm				835SG	835SG	835SG	835SG	
150 µm			835G	835G	835G	835G	835G	835G
40 µm				835F				
20 µm								
FG		314	314	314	314	314	314	314
FGS		313						
W RA		204	204	204				
ISO Ø	007	008	009	010	012	014	016	018

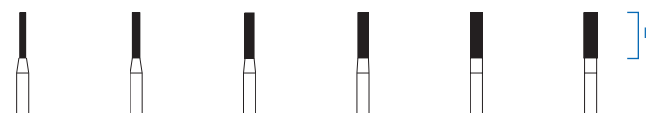

836

110



Ø mm	0,8	1,0	1,2	1,4	1,6	1,8
L mm	6,0	6,0	6,0	6,0	6,0	6,0
105-125 µm	836	836	836	836	836	836
180 µm			836SG	836SG	836SG	
150 µm		836G	836G	836G	836G	836G
40 µm		836F	836F	836F		
20 µm						
FG	314	314	314	314	314	314
FGS				313		
ISO Ø	080	010	012	014	016	018



837	Ø mm	1,0	1,2	1,4	1,6	1,8
	L mm	8,0	8,0	8,0	8,0	8,0
	105-125 µm	837	837	837	837	837
	180 µm		837SG	837SG	837SG	837SG
	150 µm	837G	837G	837G	837G	837G
	40 µm	837F	837F	837F		
	20 µm					
	FG	314*	314*	314	314	314
	FGS		313		313	
	ISO Ø	010	012	014	016	018



837L	Ø mm	1,0	1,2	1,4	1,6	1,8
	L mm	10,0	10,0	10,0	10,0	10,0
	105-125 µm	837L	837L	837L	837L	837L
	180 µm			837L-SG	837L-SG	
	150 µm	837L-G	837L-G	837L-G	837L-G	837L-G
	40 µm		837L-F			
	20 µm					
	FG	314*	314*	314*	314	314
	ISO Ø	010	012	014	016	018

* Ø max.: 300'000 / rec.: 70'000 – 140'000



838

137



Ø mm	0,8	0,9	1,0	1,2	1,4
L mm	3,0	3,0	4,0	4,0	4,0
105-125 µm	838	838	838	838	838
180 µm				838SG	
150 µm			838G	838G	838G
40 µm					
20 µm					
FG	314	314	314	314	314
ISO Ø	008	009	010	012	014

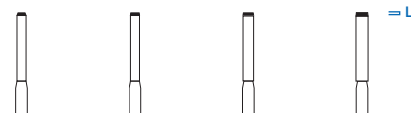

839

150



Ø mm	1,0	1,2	1,4	1,6
L mm	0,1	0,1	0,1	0,1
105-125 µm	839	839	839	839
180 µm				
150 µm				
40 µm	839F		839F	
20 µm				
FG	314	314	314	314
ISO Ø	010	012	014	016



880	Ø mm	1,0	1,2	1,4	1,6
	L mm	6,0	6,0	6,0	6,0
140					
	105-125 µm	880	880	880	880
	180 µm			880SG	
	150 µm		880G	880G	880G
	40 µm		880F	880F	
	20 µm				
	FG	314	314	314	314
	ISO Ø	010	012	014	016



881	Ø mm	1,0	1,2	1,4	1,6	1,8
	L mm	8,0	8,0	8,0	8,0	8,0
141						
	105-125 µm	881	881	881	881	881
	180 µm			881SG	881SG	881SG
	150 µm	881G	881G	881G	881G	881G
	40 µm	881F	881F	881F	881F	881F
	20 µm		881EF	881EF		
	FG	314*	314*	314	314	314
	ISO Ø	010	012	014	016	018

* Ø max.: 300'000 / rec.: 70'000 – 140'000

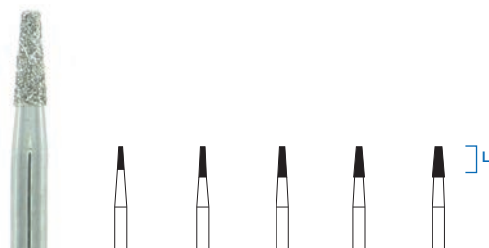

845
168

Ø mm	0,9	1,0	1,2	1,4	1,6
L mm	3,0	4,0	4,0	4,0	4,0
105-125 µm	845	845	845	845	845
180 µm					
150 µm			845G	845G	
40 µm					
20 µm					
FG	314	314	314	314	314
FGS			313		
W RA		204	204	204	
ISO Ø	009	010	012	014	016

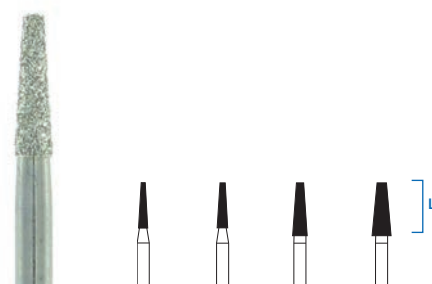

846
171

Ø mm	1,2	1,6	1,8	2,5
L mm	6,0	6,0	7,0	7,0
105-125 µm	846	846	846	846
180 µm				
150 µm	846G	846G	846G	846G
40 µm				
20 µm				
FG	314	314	314	314
ISO Ø	012	016	018	025

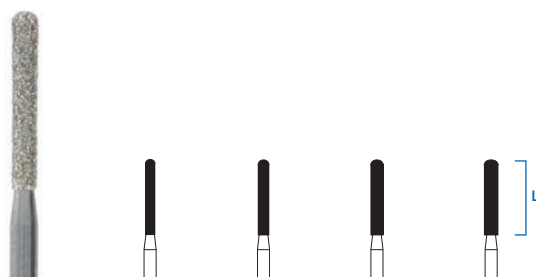

882
142

Ø mm	1,2	1,4	1,6	1,8
L mm	10,0	10,0	10,0	10,0
105-125 µm	882	882	882	882
180 µm		882SG	882SG	
150 µm	882G	882G	882G	882G
40 µm	882F	882F	882F	882F
20 µm	882EF	882EF		
FG	314*	314*	314*	314*
ISO Ø	012	014	016	018

* Ø max.: 300'000 / rec.: 70'000 – 140'000

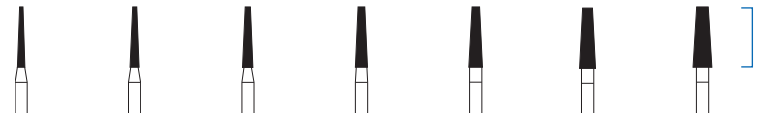

847 172	Ø mm	1,0	1,2	1,4	1,6	1,8	2,3	2,5
	L mm	8,0	8,0	8,0	8,0	8,0	8,0	8,0
	105-125 µm	847	847	847	847	847	847	847
	180 µm			847SG	847SG	847SG	847SG	
	150 µm	847G	847G	847G	847G	847G	847G	
	40 µm	847F	847F	847F	847F		847F	
	20 µm	847EF						
	FG	314*	314*	314	314	314	314	314
	FGS		313*	313				
	W RA		204	204				
	ISO Ø	010	012	014	016	018	023	025



848 173	Ø mm	1,0	1,2	1,4	1,6	1,8	2,3	3,1
	L mm	10,0	10,0	10,0	10,0	10,0	10,0	10,0
	105-125 µm	848	848	848	848	848	848	848
	180 µm			848SG	848SG	848SG	848SG	848SG
	150 µm	848G	848G	848G	848G	848G	848G	848G
	40 µm	848F	848F	848F	848F	848F	848F	
	20 µm	848EF	848EF	848EF	848EF			
	FG	314*	314*	314*	314*	314	314	314
	FGS				313*			
	ISO Ø	010	012	014	016	018	023	031

* Ø max.: 300'000 / rec.: 70'000 – 140'000

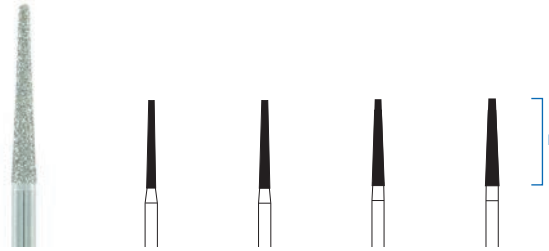

848L
174

Ø mm	1,2	1,4	1,6	1,8
L mm	11,5	11,5	11,5	11,5
105-125 µm	848L	848L	848L	848L
180 µm		848L-SG	848L-SG	848L-SG
150 µm		848L-G	848L-G	848L-G
40 µm		849F	849F	
20 µm				
FG	314*	314*	314*	314*
W RA				
ISO Ø	012	014	016	018

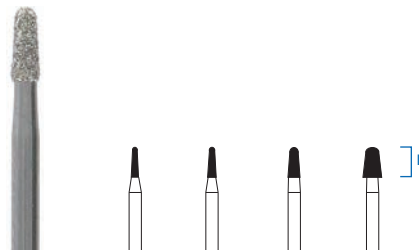

849
194

Ø mm	1,0	1,2	1,6	2,5
L mm	4,0	4,0	4,0	4,0
105-125 µm	849	849	849	849
180 µm				
150 µm		849G	849G	849G
40 µm	849F	849F		
20 µm				
FG	314	314	314	314
W RA			204	204
ISO Ø	010	012	016	025

* max.: 300'000 / rec.: 70'000 – 140'000

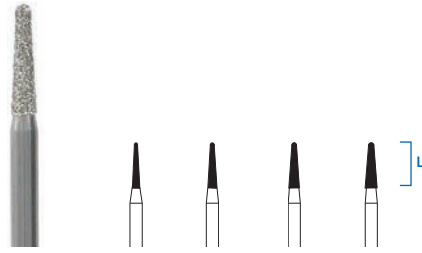

855 197	Ø mm	1,0	1,2	1,4	1,6
	L mm	6,0	6,0	6,0	6,0
	105-125 µm	855	855	855	855
	180 µm			855SG	855SG
	150 µm		855G	855G	855G
	40 µm			855F	855F
	20 µm				
	FG	314	314	314	314
	ISO Ø	010	012	014	016

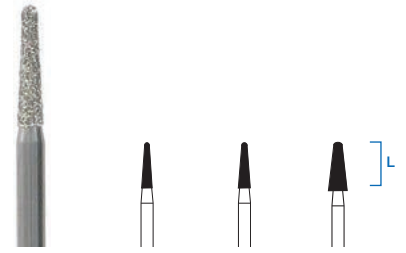

855L 197	Ø mm	1,4	1,6	2,5
	L mm	7,0	7,0	7,0
	105-125 µm	855L	855L	855L
	180 µm	855L-SG	855L-SG	855L-SG
	150 µm	855L-G	855L-G	855L-G
	40 µm	855L-F		
	20 µm			
	FG	314	314	314
	ISO Ø	014	016	025

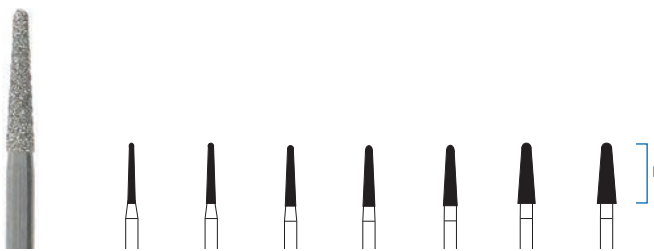

856 198	Ø mm	1,0	1,2	1,4	1,6	1,8	2,1	2,5
	L mm	8,0	8,0	8,0	8,0	8,0	8,0	8,5
	105-125 µm	856	856	856	856	856	856	856
	180 µm		856SG		856SG	856SG	856SG	856SG
	150 µm		856G	856G	856G	856G	856G	856G
	40 µm	856F	856F	856F	856F	856F	856F	
	20 µm	856EF	856EF	856EF	856EF			
	FG	314*	314*	314	314	314	314	314
	FGS		313*	313				
	ISO Ø	010	012	014	016	018	021	025



856L 199	Ø mm	1,8
	L mm	9,0
	105-125 µm	856L
	180 µm	856L-SG
	150 µm	856L-G
	40 µm	856L-F
	20 µm	856L-EF
	FG	314
	FGS	
	ISO Ø	018

* ⌀ max.: 300'000 / rec.: 70'000 – 140'000



856XL	Ø mm	1,6	1,8
	L mm	12,0	12,0
105-125 µm	856XL	856XL	
180 µm			
150 µm	856XL-G	856XL-G	
40 µm			
20 µm			
FG	314*	314*	
FGS			
ISO Ø	016	018	

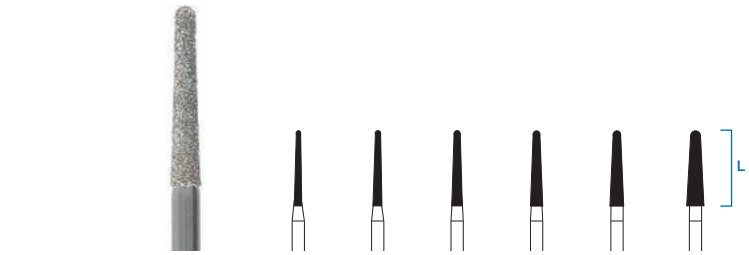

850	Ø mm	1,0	1,2	1,4	1,6	1,8	2,3
	L mm	10,0	10,0	10,0	10,0	10,0	10,0
105-125 µm	850	850	850	850	850	850	850
180 µm		850SG	850SG	850SG	850SG	850SG	850SG
150 µm	850G	850G	850G	850G	850G	850G	850G
40 µm	850F	850F	850F	850F	850F	850F	850F
20 µm	850EF	850EF	850EF	850EF	850EF		
FG	314*	314*	314*	314*	314*	314	
FGS			313*	313*	313*		
ISO Ø	010	012	014	016	018	023	

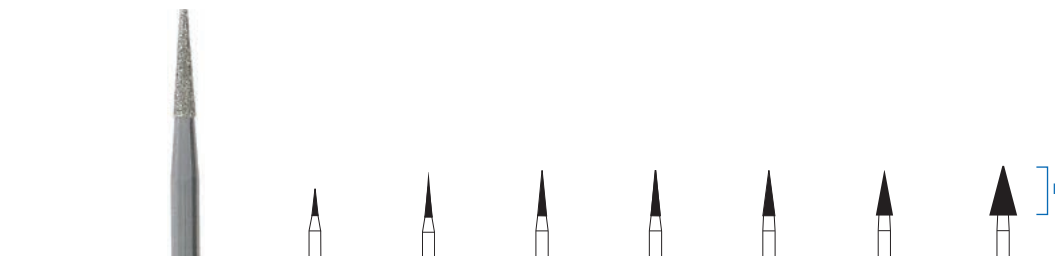

852	Ø mm	0,8	1,0	1,2	1,4	1,6	2,3	3,7
	L mm	3,5	6,0	6,0	6,0	6,0	6,0	7,0
105-125 µm	852	852	852	852	852	852	852	852
180 µm								852SG
150 µm			852G	852G	852G	852G		
40 µm		852F	852F	852F	852F	852F		
20 µm	852EF	852EF	852EF	852EF				
FG	314	314	314	314	314	314	314	
FGS					313			
ISO Ø	008	010	012	014	016	023	037	

* ⌀ max.: 300'000 / rec.: 70'000 – 140'000



858		Ø mm	1,0	1,2	1,4	1,6	1,8
165		L mm	8,0	8,0	8,0	8,0	8,0
	105-125 µm		858	858	858	858	858
	180 µm				858SG	858SG	858SG
	150 µm		858G	858G	858G	858G	858G
	40 µm		858F	858F	858F	858F	
	20 µm		858EF	858EF	858EF	858EF	
	FG		314**	314**	314**	314	314
	ISO Ø		010	012	014	016	018

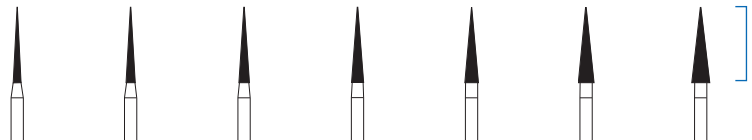

859		Ø mm	1,0	1,2	1,4	1,6	1,8	2,1	2,4
166		L mm	10,0	10,0	10,0	10,0	10,0	10,0	10,0
	105-125 µm		859	859	859	859	859	859	859
	180 µm				859SG	859SG	859SG	859SG	859SG
	150 µm		859G	859G	859G	859G	859G	859G	859G
	40 µm		859F	859F	859F	859F	859F	859F	859F
	20 µm		859EF	859EF	859EF	859EF	859EF	859EF	859EF
	FG		314**	314**	314**	314**	314**	314**	314**
	FGS		313**			313**			
	W RA					204	204		
	ISO Ø		010	012	014	016	018	021	024

** max.: 300'000 / rec.: 70'000 – 140'000



859L

167



Ø mm	1,0	1,2	1,4	1,6	1,8
L mm	11,5	11,5	11,5	11,5	11,5
105-125 µm	859L	859L	859L	859L	859L
180 µm				859L-SG	859L-SG
150 µm	859L-G	859L-G	859L-G	859L-G	859L-G
40 µm	859L-F	859L-F	859L-F	859L-F	
20 µm	859L-EF	859L-EF	859L-EF		
FG	314**	314**	314**	314**	314**
ISO Ø	010	012	014	016	018



860

247



Ø mm	1,0	1,2	1,4	1,6
L mm	4,0	4,0	5,0	5,0
105-125 µm	860	860	860	860
180 µm			860SG	860SG
150 µm	860G	860G	860G	860G
40 µm	860F	860F	860F	
20 µm	860EF	860EF		
FG	314	314	314	314
FGS			313	
W RA		204		204
ISO Ø	010	012	014	016



861

248



Ø mm	1,2	1,4
L mm	6,0	6,0
105-125 µm	861	861
180 µm		
150 µm	861G	861G
40 µm	861F	
20 µm	861EF	
FG	314*	314*
ISO Ø	012	014

* ○ max.: 160'000 / rec.: 40'000 – 85'000

** ○ max.: 300'000 / rec.: 70'000 – 140'000

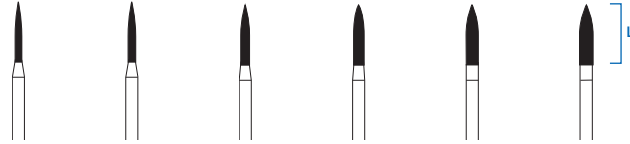

862

249



Ø mm	0,9	1,0	1,2	1,4	1,6	1,8
L mm	8,0	8,0	8,0	8,0	8,0	8,0
105-125 µm	862	862	862	862	862	862
180 µm			862SG	862SG	862SG	862SG
150 µm		862G	862G	862G	862G	862G
40 µm	862F	862F	862F	862F	862F	862F
20 µm	862EF	862EF	862EF	862EF	862EF	862EF
FG	314*	314*	314*	314*	314*	314
FGS			313*		313*	
W RA			204		204	
ISO Ø	009	010	012	014	016	018



863

250



Ø mm	1,0	1,2	1,4	1,6	1,8
L mm	10,0	10,0	10,0	10,0	10,0
105-125 µm	863	863	863	863	863
180 µm		863SG	863SG	863SG	863SG
150 µm		863G	863G	863G	863G
40 µm	863F	863F	863F	863F	863F
20 µm	863EF	863EF	863EF	863EF	
FG	314*	314*	314	314	314
W RA		204		204	
ISO Ø	010	012	014	016	018

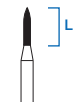

876

535



Ø mm	0,9
L mm	5,0
105-125 µm	876
180 µm	
150 µm	
40 µm	
20 µm	
FG	314**
ISO Ø	009

* Ø max.: 160'000 / rec.: 40'000 – 85'000

** Ø max.: 300'000 / rec.: 70'000 – 140'000

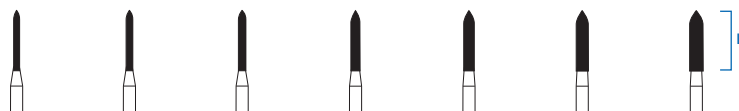

878
289

Ø mm	0,8	0,9	1,0	1,2	1,4	1,6	1,8
L mm	8,0	8,0	8,0	8,0	8,0	8,0	8,0
105-125 µm	878	878	878	878	878	878	878
180 µm				878SG	878SG	878SG	878SG
150 µm			878G	878G	878G	878G	878G
40 µm	878F		878F	878F	878F	878F	
20 µm	878EF		878EF		878EF		
FG	314*	314*	314*	314*	314	314	314
ISO Ø	008	009	010	012	014	016	018

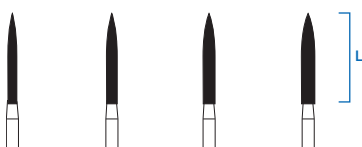

864
251

Ø mm	1,2	1,4	1,6	1,8
L mm	12,0	12,0	12,0	12,0
105-125 µm	864	864	864	864
180 µm		864SG	864SG	864SG
150 µm	864G	864G	864G	864G
40 µm	864F	864F	864F	
20 µm	864EF	864EF	864EF	
FG	314*	314*	314*	314*
ISO Ø	012	014	016	018

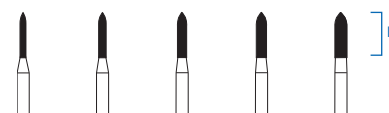

877
288

Ø mm	0,8	1,0	1,2	1,4	1,6
L mm	6,0	6,0	6,0	6,0	6,0
105-125 µm	877	877	877	877	877
180 µm			877SG	877SG	877SG
150 µm	877G	877G	877G	877G	877G
40 µm	877F	877F	877F		
20 µm					
FG	314*	314*	314*	314*	314*
FGS			313*	313*	313*
ISO Ø	008	010	012	014	016

* ⌀ max.: 160'000 / rec.: 40'000 – 85'000



879

290



Ø mm	1,0	1,2	1,4	1,6	1,8
L mm	10,0	10,0	10,0	10,0	10,0
105-125 µm	879	879	879	879	879
180 µm		879SG	879SG	879SG	879SG
150 µm	879G	879G	879G	879G	879G
40 µm	879F	879F	879F	879F	879F
20 µm	879EF	879EF	879EF	879EF	879EF
FG	314*	314*	314**	314**	314**
ISO Ø	010	012	014	016	018



884

129



Ø mm	1,0	1,2
L mm	6,0	6,0
105-125 µm	884	884
180 µm		
150 µm	884G	
40 µm	884F	884F
20 µm		
FG	314	314
ISO Ø	010	012



885

130



Ø mm	1,0	1,2	1,4	1,6
L mm	8,0	8,0	8,0	8,0
105-125 µm	885	885	885	885
180 µm		885SG	885SG	885SG
150 µm		885G	885G	885G
40 µm	885F	885F	885F	885F
20 µm				
FG	314**	314**	314**	314**
FGS		313**		
ISO Ø	010	012	014	016

* Ø max.: 160'000 / rec.: 40'000 – 85'000

** Ø max.: 300'000 / rec.: 70'000 – 140'000

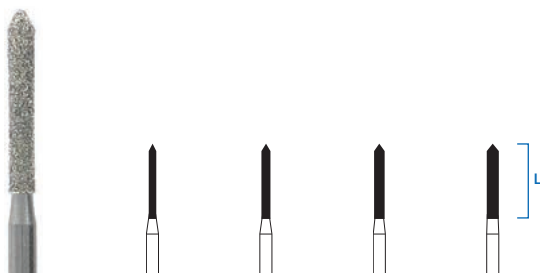

886
131

Ø mm	1,0	1,2	1,4	1,6
L mm	10,0	10,0	10,0	10,0
105-125 µm	886	886	886	886
180 µm		886SG	886SG	886SG
150 µm		886G	886G	886G
40 µm	886F	886F	886F	886F
20 µm				
FG	314	314*	314**	314**
ISO Ø	010	012	014	016



888
496

Ø mm	1,2
L mm	8,0
105-125 µm	888
180 µm	
150 µm	888G
40 µm	888F
20 µm	
FG	314**
ISO Ø	012

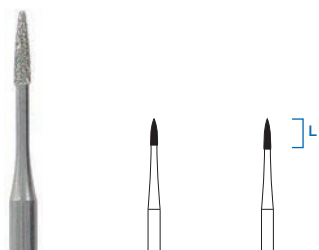

889
540

Ø mm	0,9	1,0
L mm	3,5	4,0
105-125 µm	889	889
180 µm		889SG
150 µm	889G	889G
40 µm	889F	889F
20 µm	889EF	889EF
FG	314**	314**
ISO Ø	009	010



898
213

Ø mm	1,6
L mm	10,5
105-125 µm	898
180 µm	
150 µm	898G
40 µm	898F
20 µm	
FG	314
ISO Ø	016

** max.: 300'000 / rec.: 70'000 – 140'000



368

257



Ø mm	1,0	1,4	1,6	1,8	2,1	2,3
L mm	3,5	3,5	3,5	4,5	5,0	5,0
■ 105-125 µm	368	368	368	368	368	368
■ 180 µm			368SG	368SG		368SG
■ 150 µm		368G	368G	368G		368G
■ 40 µm	368F	368F	368F	368F	368F	368F
■ 20 µm	368EF	368EF	368EF	368EF	368EF	368EF
FG	314	314	314	314	314	314
FGS			313			313
W RA			204			204
ISO Ø	010	014	016	018	021	023

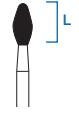

369

263



Ø mm	2,5
L mm	5,5
■ 105-125 µm	369
■ 180 µm	
■ 150 µm	369G
■ 40 µm	369F
■ 20 µm	369EF
FG	314
ISO Ø	025

Interdental Ausarbeitung
Interproximal trimming

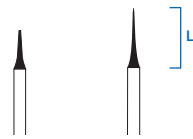

392

465



Ø mm	1,6	1,8
L mm	6,0	8,0
■ 105-125 µm	392	392
■ 180 µm		
■ 150 µm		
■ 40 µm	392F	392F
■ 20 µm	392EF	392EF
FG	314*	314*
ISO Ø	016	018

Kavitätenrandabschräger
Cavity margin trimmer



833

466



Ø mm	2,1	3,1
L mm	3,5	3,5
■ 105-125 µm	833	833
■ 180 µm		
■ 150 µm		
■ 40 µm	833F	833F
■ 20 µm	833EF	833EF
FG	314*	314*
ISO Ø	021	031

* ⌀ max.: 160'000 / rec.: 40'000 – 85'000

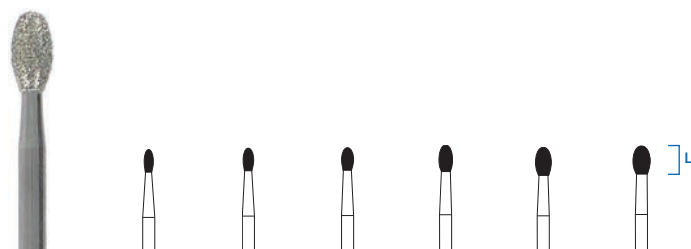

379
277

Ø mm	1,2	1,4	1,6	1,8	2,1	2,3
L mm	3,0	3,0	3,5	3,5	4,2	4,5
105-125 µm	379	379	379	379	379	379
180 µm			379SG	379SG	379SG	379SG
150 µm	379G	379G	379G	379G	379G	379G
40 µm	379F	379F	379F	379F	379F	379F
20 µm	379EF	379EF	379EF	379EF	379EF	379EF
FG	314	314	314	314	314	314
ISO Ø	012	014	016	018	021	023



390
274

Ø mm	1,4	1,6
L mm	3,5	3,5
105-125 µm	390	390
180 µm		
150 µm		
40 µm	390F	390F
20 µm	390EF	390EF
FG	314	314
ISO Ø	014	016

Kürettage
Curettage

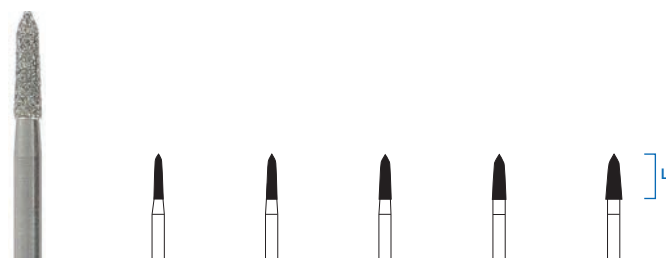

877K
297

Ø mm	1,2	1,4	1,6	1,8	2,1
L mm	6,0	6,0	6,0	6,0	6,0
105-125 µm	877K	877K	877K	877K	877K
180 µm			877K-SG	877K-SG	877K-SG
150 µm	877K-G	877K-G	877K-G	877K-G	877K-G
40 µm	877K-F	877K-F	877K-F		
20 µm					
FG	314	314	314	314	314
ISO Ø	012	014	016	018	021



Kürettage
Curettage



878K

298



Ø mm	1,2	1,4	1,6	1,8	2,1	2,3
L mm	8,0	8,0	8,0	8,0	8,0	8,0
105-125 µm	878K	878K	878K	878K	878K	878K
180 µm	878K-SG	878K-SG	878K-SG	878K-SG	878K-SG	878K-SG
150 µm	878K-G	878K-G	878K-G	878K-G	878K-G	878K-G
40 µm	878K-F	878K-F	878K-F	878K-F	878K-F	878K-F
20 µm						
FG	314*	314	314	314	314	314
FGS	313*					
ISO Ø	012	014	016	018	021	023

Kürettage
Curettage



879K

299





Ø mm	1,2	1,4	1,6	1,8	2,1	2,3
L mm	10,0	10,0	10,0	10,0	10,0	10,0
105-125 µm	879K	879K	879K	879K	879K	879K
180 µm	879K-SG	879K-SG	879K-SG	879K-SG	879K-SG	879K-SG
150 µm	879K-G	879K-G	879K-G	879K-G	879K-G	879K-G
40 µm	879K-F	879K-F	879K-F	879K-F		
20 µm						
FG	314*	314*	314*	314*	314*	314*
ISO Ø	012	014	016	018	021	023

* ⌀ max.: 300'000 / rec.: 70'000 – 140'000





851
219



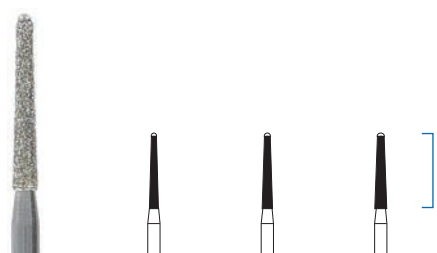

Ø mm	1,2	1,6
L mm	8,0	8,0
■ 105-125 µm	851	851
■ 180 µm		
■ 150 µm	851G	851G
■ 40 µm	851F	
■ 20 µm		
FG	314*	314*
		
ISO Ø	012	016





857
220





Ø mm	1,2	1,4	1,6
L mm	10,0	10,0	10,0
■ 105-125 µm	857	857	857
■ 180 µm		857SG	
■ 150 µm	857G	857G	857G
■ 40 µm		857F	
■ 20 µm			
FG	314*	314*	314*
			
ISO Ø	012	014	016



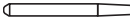

850V
199



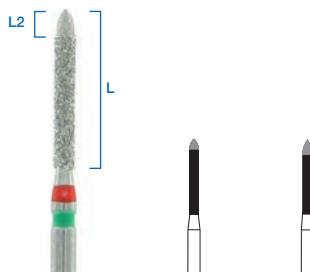

Ø mm	1,4	1,6
L mm	10,0	10,0
L2 mm	1,5	1,5
■ ■ GF	850V	850V
FG	314*	314*
		
ISO Ø	014	016



879V
290

Ø mm	1,2	1,4
L mm	10,0	10,0
L2 mm	1,5	1,5
■ ■ GF	879V	879V
FG	314*	314*
		
ISO Ø	012	014

* max.: 300'000 / rec.: 70'000 – 140'000



In-/On-/Overlay
In-/On-/Overlay



835KR

156



Ø mm	0,8	1,0	1,2	1,4	1,6
L mm	3,0	4,0	4,0	4,0	4,0
105-125 µm	835KR	835KR	835KR	835KR	835KR
180 µm		835KR-SG	835KR-SG	835KR-SG	835KR-SG
150 µm		835KR-G	835KR-G	835KR-G	835KR-G
40 µm		835KR-F	835KR-F	835KR-F	
20 µm					
FG	314	314	314	314	314
ISO Ø	008	010	012	014	016

In-/On-/Overlay
In-/On-/Overlay



836KR

157



Ø mm	0,8	1,0	1,2	1,4	1,6	1,8
L mm	6,0	6,0	6,0	6,0	6,0	6,0
105-125 µm	836KR	836KR	836KR	836KR	836KR	836KR
180 µm			836KR-SG	836KR-SG	836KR-SG	
150 µm		836KR-G	836KR-G	836KR-G	836KR-G	836KR-G
40 µm		836KR-F	836KR-F	836KR-F		
20 µm						
FG	314	314	314	314	314	314
ISO Ø	008	010	012	014	016	018



837KR
158

In-/On-/Overlay
In-/On-/Overlay

Ø mm	1,0	1,2	1,4	1,6	1,8
L mm	8,0	8,0	8,0	8,0	8,0
105-125 µm	837KR	837KR	837KR	837KR	837KR
180 µm		837KR-SG	837KR-SG	837KR-SG	837KR-SG
150 µm		837KR-G	837KR-G	837KR-G	837KR-G
40 µm	837KR-F	837KR-F	837KR-F	837KR-F	
20 µm					
FG	314	314	314	314	314
ISO Ø	010	012	014	016	018

845KR
544

In-/On-/Overlay
In-/On-/Overlay

Ø mm	1,6	1,8	2,3	2,5
L mm	4,0	4,0	4,0	4,0
105-125 µm	845KR	845KR	845KR	845KR
180 µm				
150 µm	845KR-G	845KR-G	845KR-G	845KR-G
40 µm	845KR-F	845KR-F	845KR-F	845KR-F
20 µm				
FG	314	314	314	314
ISO Ø	016	018	023	025



In-/On-/Overlay
In-/On-/Overlay



846KR

545



Ø mm	1,6	1,8
L mm	6,0	6,0
105-125 µm	846KR	846KR
180 µm		
150 µm	846KR-G	846KR-G
40 µm	846KR-F	846KR-F
20 µm		
FG	314	314
ISO Ø	016	018

In-/On-/Overlay
In-/On-/Overlay



847KR

546



Ø mm	1,4	1,6	1,8	2,3
L mm	8,0	8,0	8,0	8,0
105-125 µm	847KR	847KR	847KR	847KR
180 µm				
150 µm	847KR-G	847KR-G	847KR-G	847KR-G
40 µm	847KR-F	847KR-F	847KR-F	847KR-F
20 µm				
FG	314	314	314	314
ISO Ø	014	016	018	021



878KP



Ø mm	1,8	2,1
L mm	9,0	9,0
L2 mm	0,6	0,6
105-125 µm	878KP	878KP
180 µm		
150 µm		
40 µm	878KP-F	878KP-F
20 µm		
FG	314	314
ISO Ø	018	021



882P



Ø mm	1,2	1,4	1,6
L mm	10,0	10,0	10,0
L2 mm	0,6	0,6	0,6
105-125 µm	882P	882P	882P
180 µm			
150 µm			
40 µm	882P-F	882P-F	882P-F
20 µm			
FG	314	314	314
ISO Ø	012	014	016



Speedies
Speedies



830LS

235



Ø mm	1,2	1,4	1,6
L mm	4,0	5,0	5,0
105-125 µm			
180 µm		830LS-SG	830LS-SG
150 µm	830LS-G	830LS-G	830LS-G
40 µm			
20 µm			
FG	314	314	314
ISO Ø	012	014	016

Speedies
Speedies

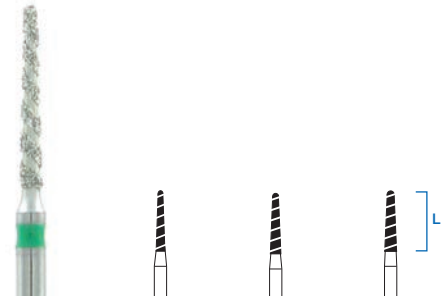

856S

198



Ø mm	1,2	1,4	1,6
L mm	8,0	8,0	8,0
105-125 µm			
180 µm		856S-SG	856S-SG
150 µm	856S-G	856S-G	856S-G
40 µm			
20 µm			
FG	314*	314*	314*
ISO Ø	012	014	016

Speedies
Speedies

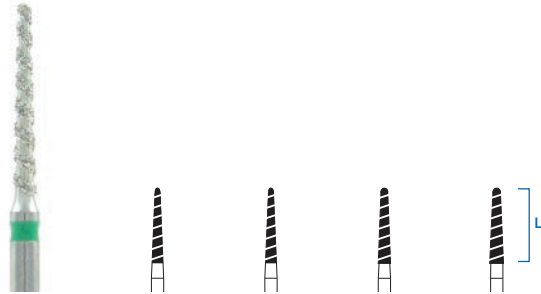

850S

199



Ø mm	1,2	1,4	1,6	1,8
L mm	10,0	10,0	10,0	10,0
105-125 µm				
180 µm		850S-SG	850S-SG	850S-SG
150 µm	850S-G	850S-G	850S-G	850S-G
40 µm				
20 µm				
FG	314*	314*	314*	314*
ISO Ø	012	014	016	018

Speedies
Speedies

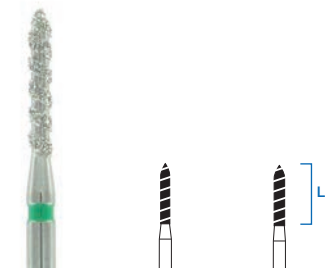

878S

289



Ø mm	1,2	1,4
L mm	8,0	8,0
105-125 µm		
180 µm	878S-SG	878S-SG
150 µm	878S-G	878S-G
40 µm		
20 µm		
FG	314*	314*
ISO Ø	012	014

* max.: 300'000



879S
290

Ø mm	1,2	1,4	1,6
L mm	10,0	10,0	10,0
105-125 µm			
180 µm	879S-SG	879S-SG	879S-SG
150 µm	879S-G	879S-G	879S-G
40 µm			
20 µm			
FG	314*	314*	314*
ISO Ø	012	014	016



879LS
290

Ø mm	1,2	1,4
L mm	12,0	12,0
105-125 µm		
180 µm	879LS-SG	879LS-SG
150 µm	879LS-G	879LS-G
40 µm		
20 µm		
FG	314*	314*
ISO Ø	012	014

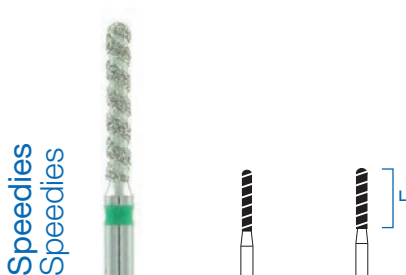

881S
141

Ø mm	1,2	1,4
L mm	8,0	8,0
105-125 µm		
180 µm		881S-SG
150 µm	881S-G	881S-G
40 µm		
20 µm		
FG	314*	314*
ISO Ø	012	014

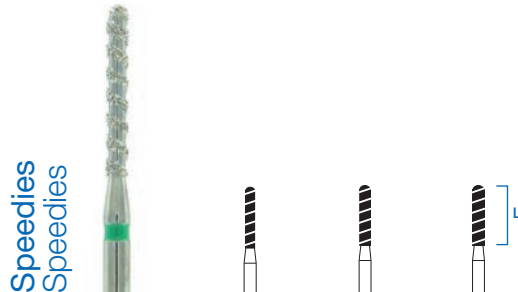

882S
141

Ø mm	1,2	1,4	1,6
L mm	10,0	10,0	10,0
105-125 µm			
180 µm		882S-SG	882S-SG
150 µm	882S-G	882S-G	882S-G
40 µm			
20 µm			
FG	314*	314*	314*
ISO Ø	012	014	016

* max.: 300'000

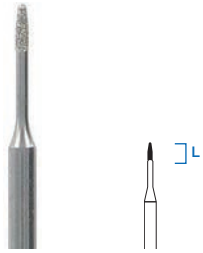

889M

Ø mm	0,7
L mm	2,7



105-125 µm	889M
180 µm	
150 µm	
40 µm	889M-F
20 µm	

FG	314**
----	-------

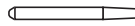

ISO Ø	007
-------	-----



838M

Ø mm	0,7
L mm	2,7



105-125 µm	838M
180 µm	
150 µm	
40 µm	838M-F
20 µm	

FG	314**
----	-------

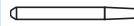

ISO Ø	007
-------	-----

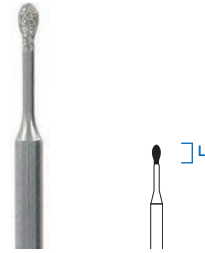

830M

Ø mm	1,2
L mm	2,7



105-125 µm	830M
180 µm	
150 µm	
40 µm	830M-F
20 µm	

FG	314*
----	------



ISO Ø	012
-------	-----



830RM

Ø mm	0,9
L mm	2,7



105-125 µm	830RM
180 µm	
150 µm	
40 µm	830RM-F
20 µm	

FG	314**
----	-------



ISO Ø	009
-------	-----



953M

Ø mm	1,4
L mm	2,0



105-125 µm	953M
180 µm	
150 µm	
40 µm	953M-F
20 µm	

FG	314*
----	------



ISO Ø	014
-------	-----

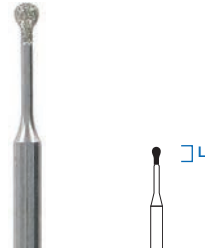

953AM

Ø mm	1,4
L mm	2,5



105-125 µm	953AM
180 µm	
150 µm	
40 µm	953AM-F
20 µm	

FG	314*
----	------



ISO Ø	014
-------	-----

* Ø max.: 160'000 / rec.: 40'000 – 85'000

** Ø max.: 300'000 / rec.: 70'000 – 140'000



831
267

Perio-Long
Perio long

Ø mm	1,2
L mm	7,0
L2 mm	28,0
105-125 µm	831
180 µm	
150 µm	
40 µm	831-F
20 µm	831-EF
WL RAL	205*
ISO Ø	012

831L
268

Perio-Long
Perio long

Ø mm	1,2
L mm	7,0
L2 mm	33,0
105-125 µm	831L
180 µm	
150 µm	
40 µm	831L-F
20 µm	831L-EF
WXL RAXL	206*
ISO Ø	012

832
258

Perio-Long
Perio long

Ø mm	1,4
L mm	5,0
L2 mm	28,0
105-125 µm	832
180 µm	
150 µm	
40 µm	832-F
20 µm	832-EF
WL RAL	205*
ISO Ø	014

832L
268

Perio-Long
Perio long

Ø mm	1,4
L mm	5,0
L2 mm	33,0
105-125 µm	832L
180 µm	
150 µm	
40 µm	832L-F
20 µm	832L-EF
WXL RAXL	206*
ISO Ø	014

* Ø max.: 10'000 / rec.: 8'000 – 9'000



T389

494



	Ø mm	1,2	1,4
	L mm	8,0	8,0
105-125 µm		T389	T389
180 µm			
150 µm			
40 µm			
20 µm			
FG		314***	314***
FGXL		316**	316**
H HP			104****
ISO Ø		012	014

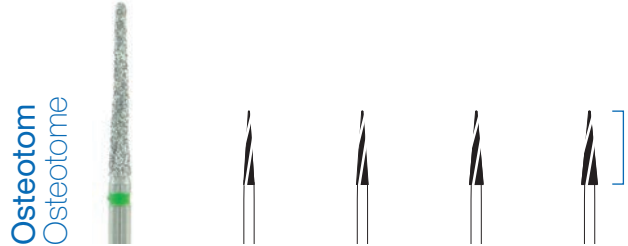

8411

411



	Ø mm	1,6	1,8	2,1	2,3
	L mm	12,0	12,0	12,0	12,0
105-125 µm					
180 µm					
150 µm		8411G	8411G	8411G	8411G
40 µm					
20 µm					
FG		314	314	314	314
W RA		204	204	204	204
H HP					104
ISO Ø		016	018	021	023



850XL



	Ø mm	1,2
	L mm	10,0
	L2 mm	30,0
105-125 µm		850XL
180 µm		850XL-SG
150 µm		850XL-G
40 µm		
20 µm		
FGXXL		317**
ISO Ø		012

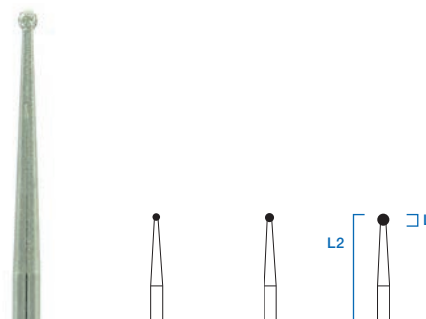

801XXL



	Ø mm	1,0	1,2	1,6
	L mm	-	-	-
	L2 mm	30,0	30,0	30,0
105-125 µm		801XXL	801XXL	801XXL
180 µm				
150 µm				
40 µm		801XXL -F	801XXL -F	801XXL -F
20 µm				
FGXXL		317*	317*	317*
ISO Ø		010	012	016

* ○ max.: 10'000

** ○ max.: 160'000

*** ○ max.: 300'000

**** ○ max.: 100'000

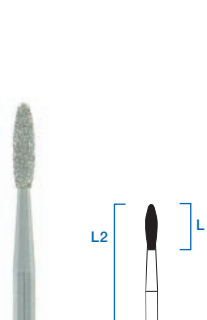
369L

Ø mm	1,6
L mm	6,0
L2 mm	25,0

4

105-125 µm 369L

180 µm

150 µm

40 µm 369L-F

20 µm

FGXL 315*



ISO Ø 016

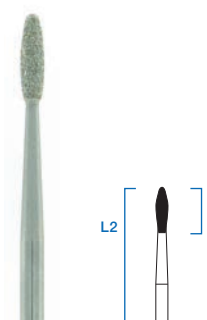

369XXL

Ø mm	1,6
L mm	6,0
L2 mm	30,0

4

105-125 µm 369XXL

180 µm

150 µm

40 µm 369XXL-F

20 µm

FGXXL 317*

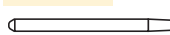

ISO Ø 016



379L

Ø mm	1,2	1,6
L mm	3,5	3,5
L2 mm	25,0	25,0

4

105-125 µm 379L 379L

180 µm

150 µm

40 µm 379L-F 379L-F

20 µm

FGL 315* 315*



ISO Ø 012 016



379XL

Ø mm	1,4	2,3
L mm	3,0	4,3
L2 mm	27,0	27,0

4

105-125 µm 379XL 379L

180 µm

150 µm 379XL-G 379XL-G

40 µm 379XL-F 379XL-F

20 µm 379XL-EF 379XL-EF

FGXL 316* 316*

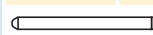

ISO Ø 014 023



379XXL

Ø mm	1,0	1,2	1,6
L mm	2,0	3,5	3,5
L2 mm	30,0	30,0	30,0

4

105-125 µm 379XXL 379XXL 379XXL

180 µm

150 µm

40 µm 379XXL-F 379XXL-F 379XXL-F

20 µm 379XXL-EF

FGXXL 317* 317* 317*

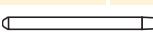

ISO Ø 010 012 016

* Ø max.: 10'000

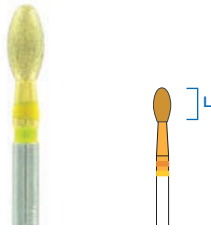

ZR379 277 	Ø mm	2,3
	L mm	4,2
	EF	ZR379EF
	FG	314*
	ISO Ø	023

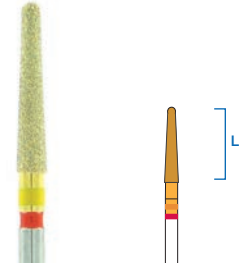

ZR850 199 	Ø mm	1,8
	L mm	10,0
	F	ZR850F
	FG	314*
	ISO Ø	018

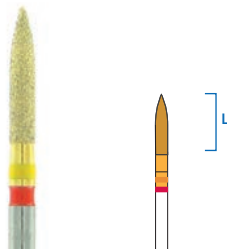

ZR862 249 	Ø mm	1,4
	L mm	8,0
	F	ZR862F
	FG	314*
	ISO Ø	014

Kronentrennen
Crown cutting

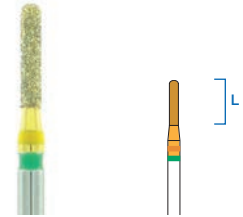

ZR880 140 	Ø mm	1,2
	L mm	6,0
	G	ZR880G
	FG	314*
	ISO Ø	012

HINWEIS

Ausreichende Wasserkühlung sicherstellen (mind. 50 ml/min.). Geringen Anpressdruck verwenden (<2 N).

NOTICE

Guarantee a sufficient water cooling (at least 50 ml per min.). Apply low contact pressure (<2 N).

* max.: 300'000 / rec.: 140'000 – 160'000



ZD379
277

Ø mm	1,8	2,3
L mm	3,5	4,5
M	ZD379-MF	ZD379-MF
F	ZD379-MFF	ZD379-MFF
EF		ZD379-FEF
FG	314*	314*
ISO Ø	018	023

ZD801L
697

Trepanation
Trepanation

Ø mm	1,2	1,8
L mm	-	-
M	ZD801L-MF	ZD801L-MF
F	ZD801L-MFF	ZD801L-MFF
EF		
FG	314*	314*
ISO Ø	012	018

ZD850
199

Ø mm	1,8
L mm	10,0
M	ZD850-MF
F	ZD850-MFF
EF	ZD850-FEF
FG	314*
ISO Ø	018

ZD862
249

Ø mm	1,6
L mm	8,0
M	ZD862-MF
F	ZD862-MFF
EF	ZD862-FEF
FG	314*
ISO Ø	016

ZD880
140



















Kronentrennen
Crown cutting

Ø mm	1,2
L mm	6,0
M	ZD880-MF
G	ZD880-GM
F	
EF	
FG	314*
ISO Ø	012

ZD889
540

Ø mm	0,7
L mm	2,7
M	ZD889-MF
G	
F	
EF	
FG	314*
ISO Ø	007

* Ø max.: 300'000 / rec.: 140'000 – 160'000

Seite Page	Laborwerkzeuge Instruments with HP shank
50	 Rund Round
53	 Birne Pear
51	 Diabolo Diabolo
51 – 52	 Umgekehrter Kegel Inverted cone
51	 Umgekehrter Kegel lang Long inverted cone
53	 Rad Wheel
54	 Linse Lenticular
53 – 55	 Zylinder Cylinder
55 – 60	 Zylinder rund Cylinder round
56	 Konisch Tapered
47	 Konisch rund Tapered round
47	 Konisch rund, lang Tapered round, long
58	 Konisch spitz Tapered pointed
60	 Nadel Needle
60	 Granate Grenade
59	 Flamme Flame
60 – 61	 Torpedo Torpedo
62	 Knospe Bud
62	 Ei Egg/Football

Seite Page	ZrO ₂ Bearbeitung ZiRoDia ZrO ₂ processing ZiRoDia
---------------	---

63 – 64	
---------	---

Seite Page	ZrO ₂ · Silikat-Keramik Bearbeitung ZrO ₂ · Silicate ceramic processing
---------------	--

65	
----	--

Seite Page	Diamant-Scheiben Diamond discs
---------------	-----------------------------------

66 – 71	
---------	---



Dental Labor Dental Laboratory

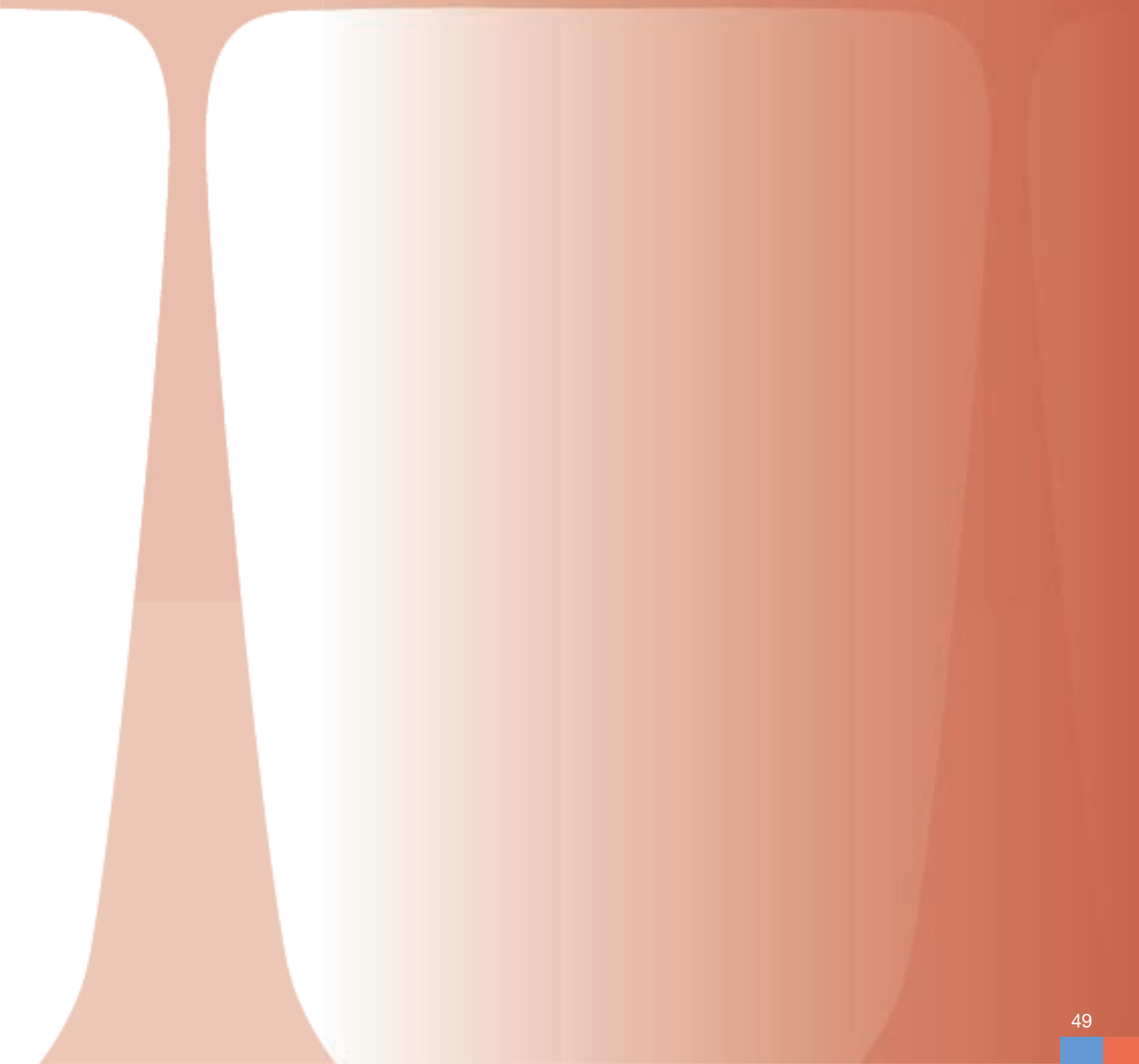

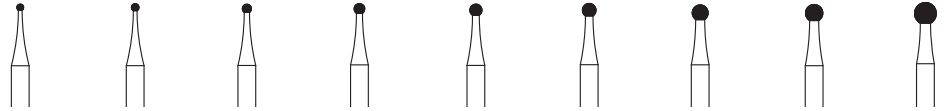

801

001



Ø mm	0,9	1,0	1,2	1,4	1,6	1,8	2,1	2,3	2,9
L mm	-	-	-	-	-	-	-	-	-
110-120 µm	801	801	801	801	801	801	801	801	801
150 µm		801G						801G	801G
40 µm									
H HP	104	104	104	104	104	104	104	104	104
ISO Ø	009	010	012	014	016	018	021	023	029

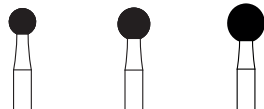
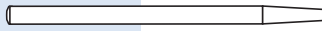

801

001



Ø mm	3,5	4,0	5,0
L mm	-	-	-
110-120 µm	801	801	801
150 µm	801G	801G	
40 µm			
H HP	104	104	104
ISO Ø	035	040	050

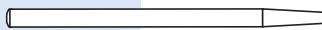

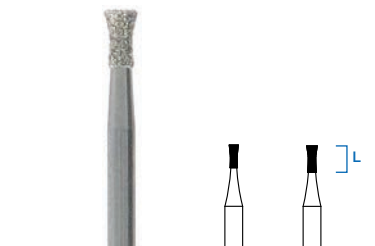
806
019

Ø mm	1,2	1,4
L mm	3,0	3,5
110-120 µm	806	806
150 µm		806G
40 µm		
H HP	104	104
ISO Ø	012	014

807
225

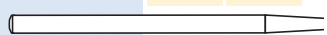
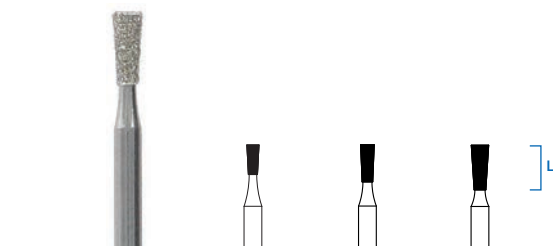
Ø mm	1,6	1,8	2,3
L mm	4,0	5,0	6,0
110-120 µm	807	807	807
150 µm			
40 µm			
H HP	104	104	104
ISO Ø	016	018	023

805
010

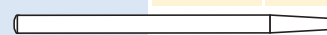
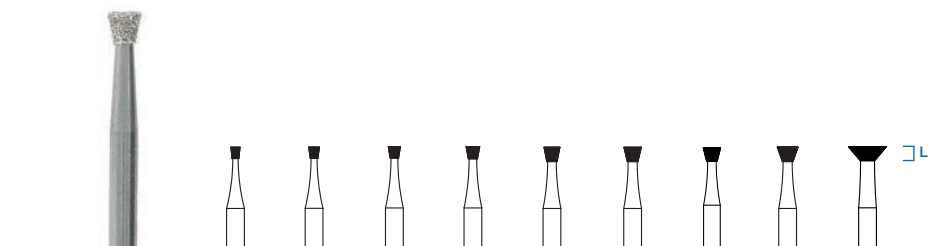
Ø mm	1,2	1,4	1,6	1,8	2,1	2,3	2,5	2,7	5,0
L mm	1,5	1,5	1,5	1,5	2,0	2,0	2,0	2,0	2,0
110-120 µm	805	805	805	805	805	805	805	805	805
150 µm									
40 µm									
H HP	104	104	104	104	104	104	104	104	104
ISO Ø	012	014	016	018	021	023	025	027	050



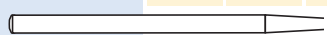

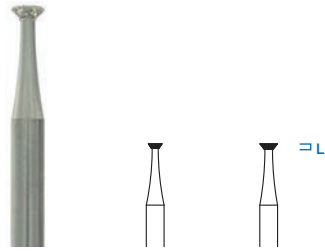
805A	Ø mm	1,8	2,3
	L mm	0,7	0,8
014			
	110-120 µm	805A	805A
	150 µm		
	40 µm		
	H HP	104	104
	ISO Ø	018	023

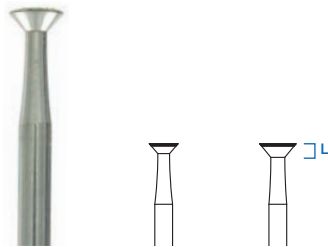

810	Ø mm	4,0	5,0
	L mm	1,5	2,0
021			
	110-120 µm	810	810
	150 µm		
	40 µm		
	H HP	104	104
	ISO Ø	040	050

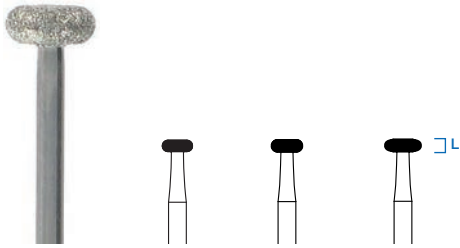

909 068 	Ø mm	4,0	4,5	5,5
	L mm	1,5	1,5	2,0
	110-120 µm	909	909	909
	150 µm			
	40 µm			
	H HP	104	104	104
	ISO Ø	040	045	055

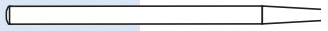

830RL 238 	Ø mm	2,3
	L mm	5,0
	110-120 µm	830RL
	150 µm	
	40 µm	
	H HP	104
	ISO Ø	023

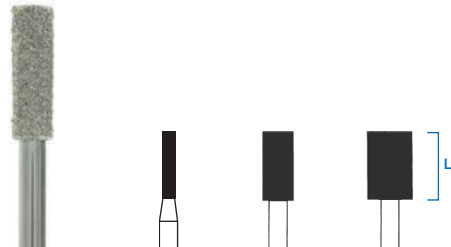
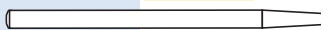

840 111 	Ø mm	1,8	4,0	7,0
	L mm	9,0	9,0	9,0
	110-120 µm	840	840	840
	150 µm			
	40 µm			
	H HP	104	104	104
	ISO Ø	018	040	070





CL

825

304



Ø mm	1,8	2,3	4,0	5,0	6,0
L mm	0,8	0,9	1,1	1,5	1,8
110-120 µm	825	825	825	825	825
150 µm					
40 µm					
H HP	104	104	104	104	104
ISO Ø	018	023	040	050	060



L

835

107



Ø mm	0,8	1,0	1,2	1,6	2,1	2,5
L mm	4,0	4,0	4,0	4,0	5,0	6,0
110-120 µm	835	835	835	835	835	835
150 µm						
40 µm						
H HP	104	104	104	104	104	104
ISO Ø	008	010	012	016	021	025



836
110
 4

Ø mm	1,2	1,4	2,7
L mm	6,0	6,0	4,0
110-120 µm	836	836	836
150 µm			
40 µm			
H HP	104	104	104
ISO Ø	012	014	027

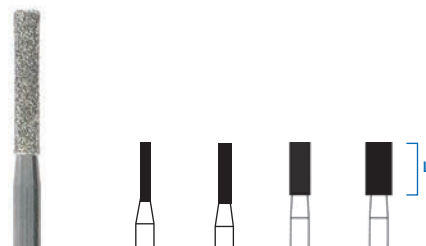

837
111
 4

Ø mm	1,4	1,6	2,7	3,3
L mm	8,0	8,0	8,0	8,0
110-120 µm	837	837	837	837
150 µm				
40 µm				
H HP	104	104	104	104
ISO Ø	014	016	027	033



842
113
 4

Ø mm	1,8
L mm	12,0
110-120 µm	842
150 µm	
40 µm	
H HP	104
ISO Ø	018



842R
143
 4

Ø mm	1,8
L mm	12,0
110-120 µm	842R
150 µm	
40 µm	
H HP	104
ISO Ø	018



845 168	Ø mm	0,8	1,0	1,8
	L mm	4,0	4,0	5,0
4	110-120 µm	845	845	845
	150 µm			
	40 µm			
	H HP	104	104	104
	ISO Ø	080	010	018

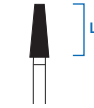
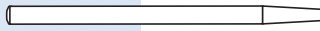

846 171	Ø mm	2,5
	L mm	7,0
4	110-120 µm	846
	150 µm	
	40 µm	
	H HP	104
	ISO Ø	025

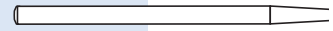

847 172	Ø mm	1,4	1,8	2,3	3,3	4,0
	L mm	8,0	8,0	8,0	9,0	9,0
4	110-120 µm	847	847	847	847	847
	150 µm					
	40 µm					
	H HP	104	104	104	104	104
	ISO Ø	014	018	023	033	040

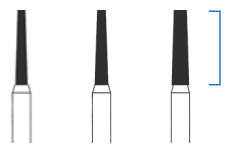
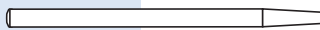

848 173	Ø mm	1,6	1,8	2,3
	L mm	10,0	10,0	10,0
4	110-120 µm	848	848	848
	150 µm		848G	848G
	40 µm			
	H HP	104	104	104
	ISO Ø	016	018	023

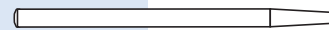

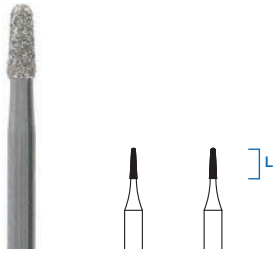

849
194

Ø mm	0,9	1,0
L mm	4,0	4,0
110-120 µm	849	849
150 µm		
40 µm		
H HP	104	104
ISO Ø	009	010

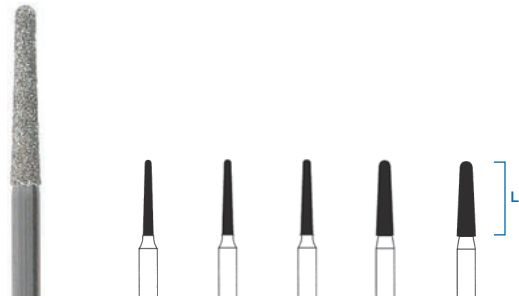

850
199

Ø mm	1,4	1,6	1,8	2,3	2,5
L mm	10,0	10,0	10,0	10,0	10,0
110-120 µm	850	850	850	850	850
150 µm					
40 µm					
H HP	104	104	104	104	104
ISO Ø	014	016	018	023	025

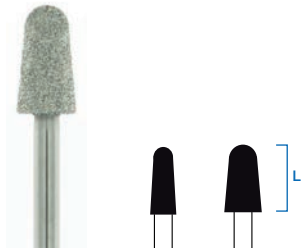

854R
172

Ø mm	3,3	4,0
L mm	9,0	9,0
110-120 µm	854R	854R
150 µm		
45 µm		
H HP	104	104
ISO Ø	033	040

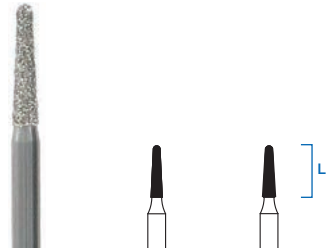

855L
197

Ø mm	1,6	2,5
L mm	7,0	7,0
110-120 µm	855L	855L
180 µm		855L-SG
150 µm	855L-G	855L-G
40 µm		
H HP	104	104
ISO Ø	016	025

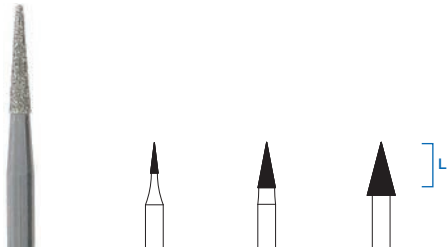

852	Ø mm	1,0	2,3	3,7
	L mm	4,0	6,0	7,0
161				
	110-120 µm	852	852	852
	180 µm			
	40 µm			
	H HP	104	104	104
	ISO Ø	010	023	037

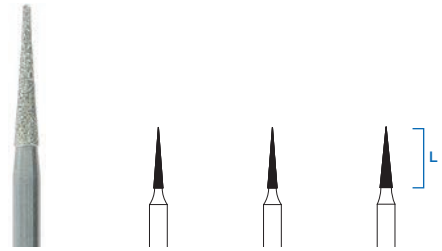

858	Ø mm	1,2	1,4	1,6
	L mm	8,0	8,0	8,0
165				
	110-120 µm	858	858	858
	180 µm			
	40 µm	858F	858F	858F
	H HP	104	104	104
	ISO Ø	012	014	016

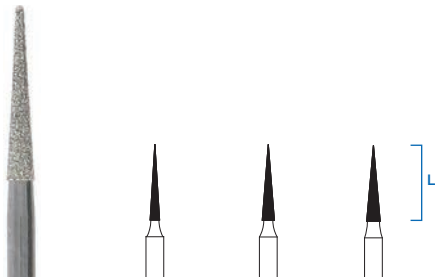

859	Ø mm	1,0	1,6	1,8
	L mm	10,0	10,0	10,0
166				
	110-120 µm	859	859	859
	180 µm			
	40 µm	859F	859F	859F
	H HP	104	104	104
	ISO Ø	010	016	018

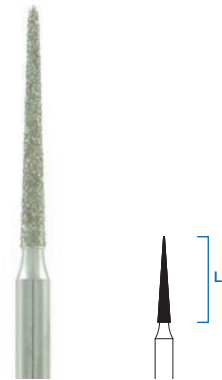

859L	Ø mm	1,6
	L mm	12
167		
	110-120 µm	859L
	180 µm	
	40 µm	859L-F
	H HP	104
	ISO Ø	016

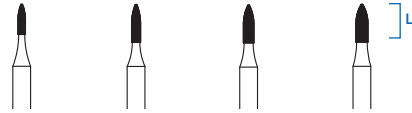

860	Ø mm	1,0	1,2	1,4	1,6
	L mm	4,0	5,0	5,0	5,0
245					
	110-120 µm	860	860	860	860
	180 µm				
	40 µm	860F	860F	860F	860F
	H HP	104	104	104	104
	ISO Ø	010	012	014	016



862	Ø mm	1,4	1,8	2,3
	L mm	8,0	8,0	8,0
249				
	110-120 µm	862	862	862
	80 µm	862SG	862SG	862SG
	180 µm			
	40 µm			
	H HP	104	104	104
	ISO Ø	014	018	023

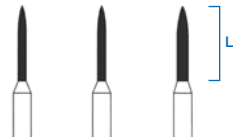

863	Ø mm	1,2	1,6	2,3
	L mm	10,0	10,0	10,0
250				
	110-120 µm	863	863	863
	180 µm	863G	863G	863G
	40 µm			
	H HP	104	104	104
	ISO Ø	012	016	023

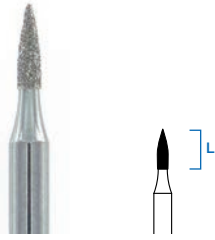

867	Ø mm	1,4
	L mm	5,0
496		
	110-120 µm	867
	180 µm	
	40 µm	867F
	H HP	104
	ISO Ø	014

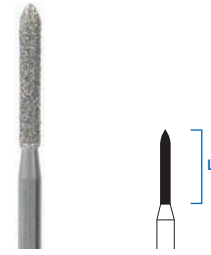

879	Ø mm	1,4
	L mm	10,0
290		
	110-120 µm	879
	180 µm	
	40 µm	
	H HP	104
	ISO Ø	014

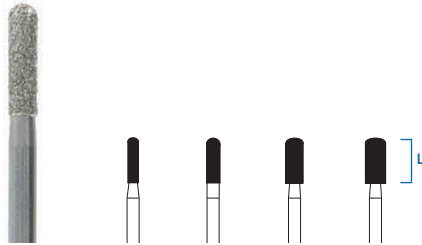

880	Ø mm	1,4	1,8	2,3	2,7
	L mm	6,0	6,0	6,0	6,0
140					
	110-120 µm	880	880	880	880
	180 µm				
	40 µm				
	H HP	104	104	104	104
	ISO Ø	014	018	023	027

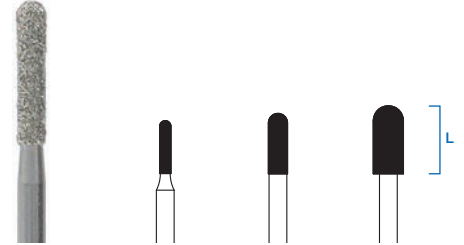

881	Ø mm	1,6	2,5	4,0
	L mm	7,0	8,0	9,0
141				
	110-120 µm	881	881	881
	180 µm			
	40 µm			
	H HP	104	104	104
	ISO Ø	016	025	040

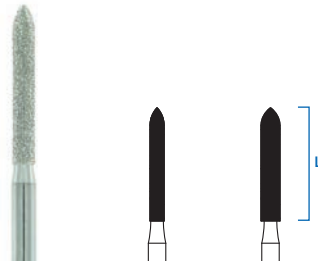

892	Ø mm	2,0	2,5
	L mm	15,0	15,0
299			
	110-120 µm	892	892
	180 µm		
	40 µm		
	H HP	104	104
	ISO Ø	020	025



890	Ø mm	1,6
	L mm	3,5
271		
	110-120 µm	890
	180 µm	
	40 µm	
	H HP	104
	ISO Ø	016



366	Ø mm	1,2	1,6
	L mm	1,8	2,5
254			
	110-120 µm	366	366
	180 µm		
	40 µm		
	H HP	104	104
	ISO Ø	012	016

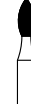

368	Ø mm	2,3	
	L mm	5,0	
257			
	110-120 µm	368	
	180 µm		
	40 µm		
	H HP	104	
	ISO Ø	023	



379	Ø mm	1,4	2,3
	L mm	2,8	4,2
277			
	110-120 µm	379	379
	180 µm		
	40 µm		
	H HP	104	104
	ISO Ø	014	023



Nassbearbeitung
Wet processing

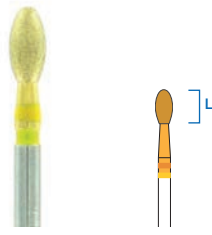

ZR379 277 	Ø mm	2,3
	L mm	4,5
	EF	ZR379EF
	FG	314*
	ISO Ø	023

Nassbearbeitung
Wet processing

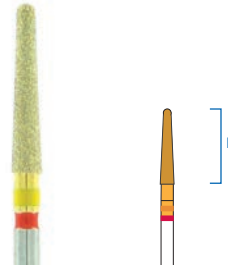

ZR850 199 	Ø mm	1,8
	L mm	10,0
	F	ZR850F
	FG	314*
	ISO Ø	018

Nassbearbeitung
Wet processing

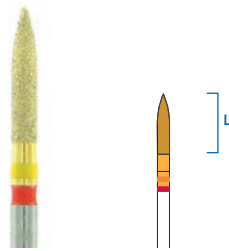

ZR862 249 	Ø mm	1,4
	L mm	8,0
	F	ZR862F
	FG	314*
	ISO Ø	014

Nassbearbeitung
Wet processing

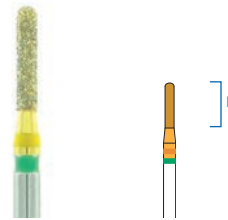

ZR880 140 	Ø mm	1,2
	L mm	6,0
	G	ZR880G
	FG	314*
	ISO Ø	012

HINWEIS

Ausreichende Wasserkühlung sicherstellen (mind. 50 ml/min.). Geringen Anpressdruck verwenden (< 2 N).

NOTICE

Guarantee a sufficient water cooling (at least 50 ml per min.). Apply low contact pressure (< 2 N).

* max.: 300'000 / rec.: 140'000 – 160'000

Nassbearbeitung
Wet processing

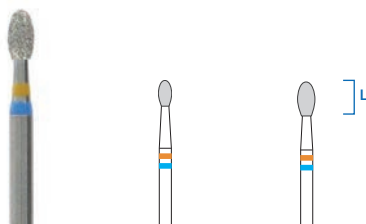

ZD379 277	Ø mm	1,8	2,3
	L mm	3,5	4,5
	M	ZD379-MF	ZD379-MF
	F	ZD379-MFF	ZD379-MFF
	EF		ZD379-FEF
FG	314*		314*
ISO Ø	018	023	

Nassbearbeitung
Wet processing

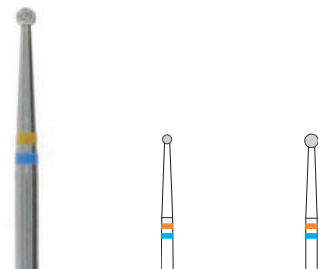

ZD801L 001	Ø mm	1,2	1,8
	L mm	-	-
	M	ZD801L-MF	ZD801L-MF
	F	ZD801L-MFF	ZD801L-MFF
	EF		
FG	314*		314*
ISO Ø	012	018	

Nassbearbeitung
Wet processing

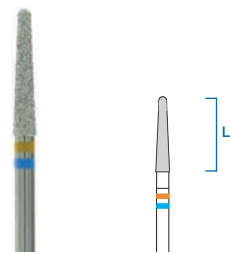

ZD850 199	Ø mm	1,8
	L mm	10,0
	M	ZD850-MF
	F	ZD850-MFF
	EF	ZD850-FEF
FG	314*	
ISO Ø	018	

Nassbearbeitung
Wet processing

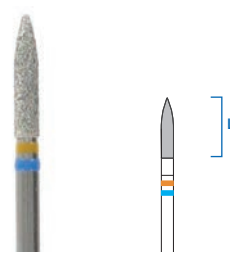

ZD862 249	Ø mm	1,6
	L mm	8,0
	M	ZD862-MF
	F	ZD862-MFF
	EF	ZD862-FEF
FG	314*	
ISO Ø	016	

Nassbearbeitung
Wet processing

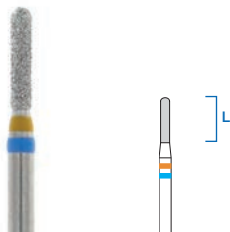

ZD880 140	Ø mm	1,2
	L mm	6,0
	M	ZD880-MF
	G	ZD880-GM
FG	314*	
ISO Ø	012	

Nassbearbeitung
Wet processing



ZD889 540	Ø mm	0,7
	L mm	2,7
	M	ZD889-MF
FG	314*	
ISO Ø	007	

* Ø max.: 300'000 / rec.: 140'000 – 180'000



ZR801
001

Trockenbearbeitung
Dry processing

Ø mm	0,9
L mm	-
M	ZR801M
H HP	104**
ISO Ø	009

ZR805
010

Trockenbearbeitung
Dry processing

Ø mm	1,6
L mm	1,5
M	ZR805M
H HP	104**
ISO Ø	016

ZR805A
014

Trockenbearbeitung
Dry processing

Ø mm	1,8
L mm	0,7
M	ZR805A-M
H HP	104**
ISO Ø	018

ZD801
001

Trockenbearbeitung
Dry processing

Ø mm	0,9	1,0
L mm	-	-
M	ZD801-MF	ZD801-MF
H HP	104**	104**
ISO Ø	009	010

ZD805
010

Trockenbearbeitung
Dry processing

Ø mm	1,6
L mm	1,5
M	ZD805-MF
H HP	104**
ISO Ø	016

ZD863
250

Trockenbearbeitung
Dry processing

Ø mm	1,2
L mm	10,0
M	ZD863-MF
H HP	104**
ISO Ø	012

ZD9131

Trockenbearbeitung
Dry processing

Ø mm	22,0
L mm	0,15
M	ZD9131-MF
F	ZD9131-MFF
H HP	104***
ISO Ø	220

** rec.: 10'000 – 13'000

*** rec.: 13'000

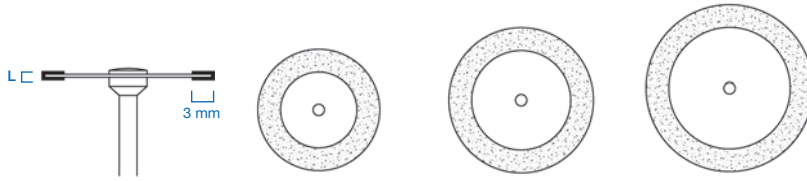



9120	Ø mm	16,0	19,0	22,0
	L mm	0,30	0,30	0,30
340				
	75 µm	9120	9120	9120
	H HP	104	104	104
	ISO Ø	160	190	220

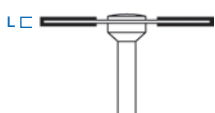

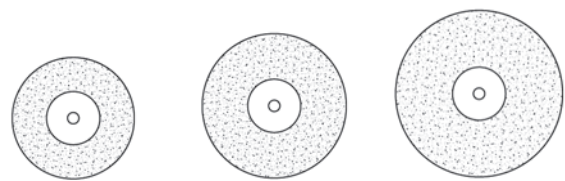
LC 





9220 345	Ø mm	16,0	19,0	22,0
	L mm	0,30	0,30	0,30
	75 µm	9220	9220	9220
	H HP	104	104	104
	ISO Ø	160	190	220

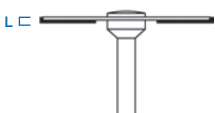

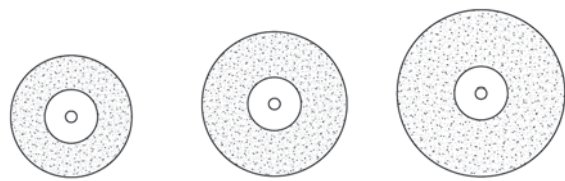
LC 



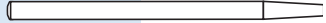

9221 346	Ø mm	16,0	19,0	22,0
	L mm	0,25	0,25	0,25
	75 µm	9221	9221	9221
	H HP	104	104	104
	ISO Ø	160	190	220

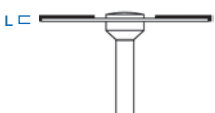

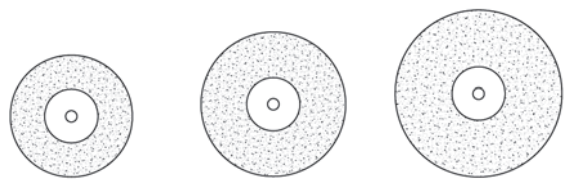
LC 



9222 347	Ø mm	16,0	19,0	22,0
	L mm	0,25	0,25	0,25
	75 µm	9222	9222	9222
	H HP	104	104	104
	ISO Ø	160	190	220



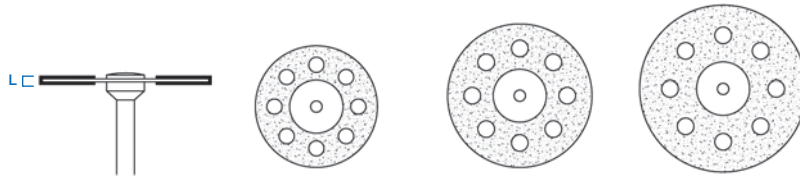

9220P	\varnothing mm	16,0	19,0	22,0
	L mm	0,30	0,30	0,30
350				
	75 μ m	9220P	9220P	9220P
	H HP	104	104	104
	ISO \varnothing	160	190	220

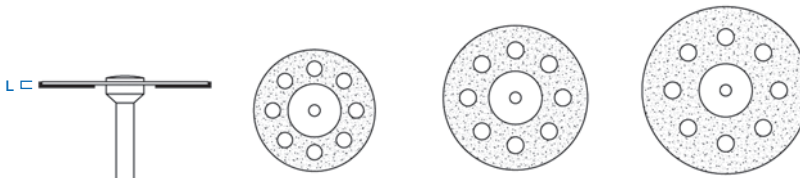

9221P	\varnothing mm	16,0	19,0	22,0
	L mm	0,25	0,25	0,25
351				
	75 μ m	9221P	9221P	9221P
	H HP	104	104	104
	ISO \varnothing	160	190	220

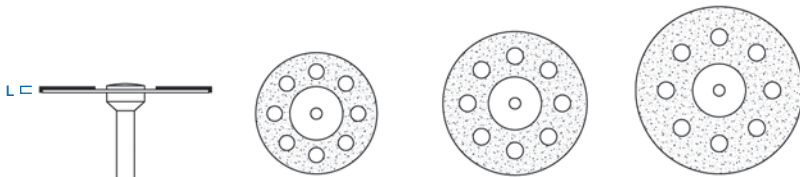

9222P	\varnothing mm	16,0	19,0	22,0
	L mm	0,25	0,25	0,25
352				
	75 μ m	9222P	9222P	9222P
	H HP	104	104	104
	ISO \varnothing	160	190	220

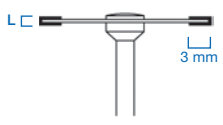
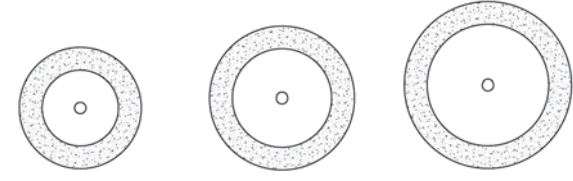

9130

355	Ø mm	16,0	19,0	22,0
	L mm	0,25	0,25	0,25
	medium 65 µm	9130	9130	9130
	L mm	0,27	0,27	0,27
	coarse 75 µm	9130-G	9130-G	9130-G
	L mm	0,20	0,20	0,20
	fine 45 µm	9130-F	9130-F	9130-F
	H HP	104	104	104
	ISO Ø	160	190	220

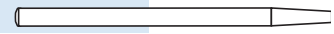

9131

356	Ø mm	16,0	19,0	22,0
	L mm	0,15	0,15	0,15
	fine 45 µm	9131-F	9131-F	9131-F
	H HP	104	104	104
	W RA		204	204
	ISO Ø	160	190	220

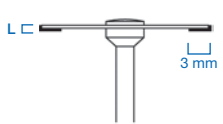
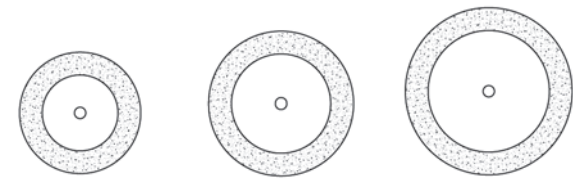

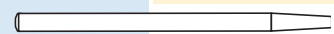
9132



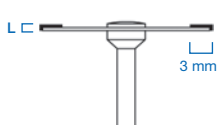
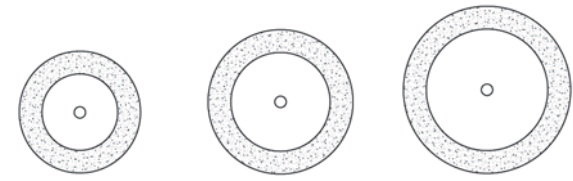

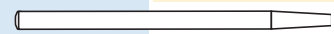
357	Ø mm	16,0	19,0	22,0
	L mm	0,15	0,15	0,15
	fine 45 µm	9132-F	9132-F	9132-F
	H HP	104	104	104
	W RA		204	204
	ISO Ø	160	190	220

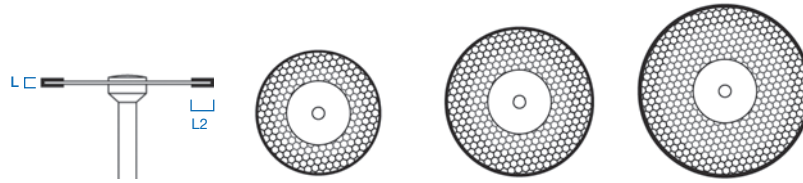

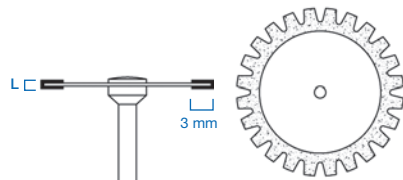

9340 355	Ø mm	14,0	18,0	22,0
	L/L2 mm	0,18/2,0	0,18/3,0	0,18/3,0
	medium	9340	9340	9340
	L/L2 mm		0,22/3,0	0,22/3,0
	coarse		9340-G	9340-G
	L/L2 mm	0,15/2,0	0,15/3,0	0,15/3,0
	fine	9340-F	9340-F	9340-F
	H HP	104	104	104
	ISO Ø	140	180	220



9120Z 365	Ø mm	22,0
	L mm	0,30
	medium 75 µm	9120Z
	L mm	0,25
	fine 45 µm	9120Z-F
	H HP	104
	ISO Ø	220

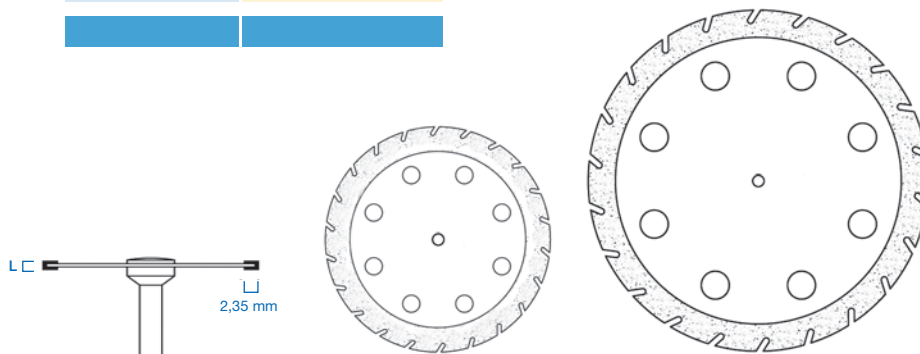

9500ZP 333	Ø mm	30,0	45,0
	L mm	0,3	0,35
	fine 45 µm	9500ZP-F	9500ZP-F
	H HP	104*	104*
	ISO Ø	300	450

* ○ max.: 20'000 / rec.: 10'000

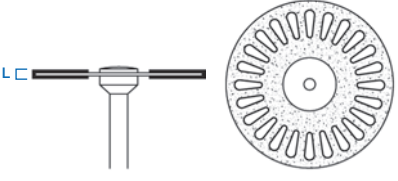
9460
405

Ø mm	22,0
L mm	0,30
medium 65 µm	9460
L mm	0,25
fine 45 µm	9460-F
H HP	104
ISO Ø	220

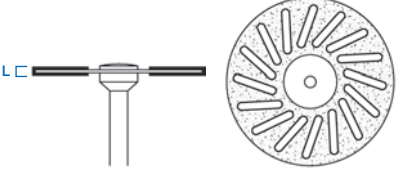

9470
605

Ø mm	22,0
L mm	0,30
medium 65 µm	9470
L mm	0,25
fine 45 µm	9470-F
H HP	104
ISO Ø	220

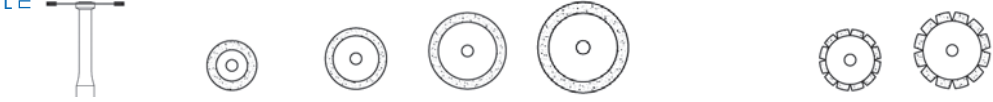

9800
361

Ø mm	6,5	8,0	10,0	13,0		
L mm		0,25	0,25			
medium 65 µm		9800	9800			
L mm	0,20	0,20	0,20	0,17		
fine 45 µm	9800-F	9800-F	9800-F	9800-F		
H HP	104	104	104	104		
W RA	204	204	204			
ISO Ø	065	080	100	130		

9800Z
325

	8,0	10,0
	0,20	0,20
	9800Z-F	9800Z-F
	104	104
	204	204
	080	100



Form Shape	ISO Nr. ohne Ø ISO no. without Ø	Seite Page
368	806 314 257... ..	32
369	806 314 263... ..	32
369L	806. 315 xxx... ..	45
369XXL	806 317 xxx... ..	45
379	806 314 277... ..	33
379L	806 315 xxx... ..	45
379XL	806 316 xxx... ..	45
379XXL	806 317 xxx... ..	45
ZD 379	806 314 277... ..	47
ZR 379	806 314 277... ..	46
T 389	806 314 494... ..	44
390	806 314 274... ..	33
392	806 314 465... ..	32
801	806 314 001... ..	1
801L	806 314 697... ..	9
801XXL	806 317 xxx... ..	44
ZD 801L	806 314 697... ..	47
802	806 314 002... ..	9
802LE	806 314 002... ..	8
805	806 314 010... ..	10
806	806 314 019... ..	11
807	806 314 225... ..	10
811	806 314 038... ..	13
813	806 314 032... ..	11
815	806 314 042... ..	14
818	806 314 041... ..	14
820	806 314 042... ..	14
825	806 314 304... ..	16
830	806 314 233... ..	12
830L	806 314 234... ..	12
830LS	806 314 235... ..	40
830M	806 314 xxx... ..	42
830RL	806 314 238... ..	13
830RM	806 314 xxx... ..	42
831	806 314 267... ..	43
831L	806 314 268... ..	43
832	806 314 258... ..	43
832L	806 314 268... ..	43
833	806 314 466... ..	32
834	806 314 552... ..	16

Form Shape	ISO Nr. ohne Ø ISO no. without Ø	Seite Page
835	806 314 107... ..	17
835KR	806 314 156... ..	36
836	806 314 110... ..	17
836KR	806 314 157... ..	36
837	806 314 111... ..	18
837L	806 314 112... ..	18
837KR	806 314 158... ..	37
838	806 314 137... ..	19
838M	806 314 xxx... ..	42
839	806 314 150... ..	19
845	806 314 168... ..	21
845KR	806 314 544... ..	37
846	806 314 171... ..	21
846KR	806 314 545... ..	38
847	806 314 172... ..	22
847KR	806 314 546... ..	38
848	806 314 173... ..	22
848L	806 314 174... ..	23
849	806 314 194... ..	23
850	806 314 199... ..	25
850S	806 314 199... ..	40
850V	806 314 219... ..	35
850XL	806 317 xxx... ..	44
ZD 850	806 314 249... ..	47
ZR 850	806 314 249... ..	46
851	806 314 219... ..	35
852	806 314 161... ..	25
855	806 314 197... ..	24
855L	806 314 xxx... ..	24
856	806 314 198... ..	24
856L	806 314 199... ..	24
856S	806 314 198... ..	40
856XL	806 314 xxx... ..	25
857	806 314 220... ..	35
858	806 314 165... ..	26
859	806 314 166... ..	26
859L	806 314 167... ..	27
860	806 314 247... ..	27
861	806 314 248... ..	27
862	806 314 249... ..	28

Form Shape	ISO Nr. ohne Ø ISO no. without Ø	Seite Page
ZD 862	806 314 140... ..	47
ZR 862	806 314 140... ..	46
863	806 314 250... ..	28
864	806 314 251... ..	29
876	806 314 535... ..	29
877	806 314 288... ..	29
877K	806 314 297... ..	33
878	806 314 289... ..	29
878K	806 314 298... ..	34
878KP	806 314 xxx... ..	39
878S	806 314 289... ..	40
879	806 314 290... ..	30
879K	806 314 299... ..	34
879LS	806 314 290... ..	41
879S	806 314 290... ..	41
879V	806 314290... ..	35
880	806 314 140... ..	20
ZD 880	806 314 xxx... ..	47
ZR 880	806 314 xxx... ..	46
881	806 314 141... ..	21
881S	806 314 141... ..	41
882	806 314 142... ..	21
882P	806 314 xxx... ..	39
882S	806 314 141... ..	41
884	806 314 129... ..	30
885	806 314 130... ..	30
886	806 314 131... ..	31
888	806 314 496... ..	31
889	806 314 540... ..	31
889M	806 314 xxx... ..	42
ZD 889	806 314 540... ..	47
898	806 314 213... ..	31
899	806 314 033... ..	15
909	806 314 068... ..	15
953AM	806 314 xxx... ..	42
953M	806 314 xxx... ..	42
8411	806 314 411... ..	44



Form Shape	ISO Nr. ohne Ø ISO no. without Ø	Seite Page
366	806 104 254... ..	62
368	806 104 257... ..	62
379	806 104 277... ..	62
ZD 379	806 314 277... ..	64
ZR 379	806 314 277... ..	63
801	806 104 001... ..	50
ZD 801	806 104 001... ..	65
ZD 801L	806 314 001... ..	64
ZR 801	806 104 001... ..	65
805	806 104 010... ..	51
805A	806 104 014... ..	52
ZD 805	806 104 010... ..	65
ZR 805	806 104 010... ..	65
ZR 805A	806 104 014... ..	65
806	806 104 019... ..	51
807	806 104 225... ..	51
810	806 104 021... ..	52
825	806 104 304... ..	54
830RL	806 104 238... ..	53
835	806 104 107... ..	54
836	806 104 110... ..	55
837	806 104 111... ..	55
840	806 104 111... ..	53
842	806 104 113... ..	55
842R	806 104 143... ..	55
845	806 104 168... ..	56
846	806 104 171... ..	56
847	806 104 172... ..	56
848	806 104 173... ..	56
849	806 104 194... ..	57
850	806 104 199... ..	57
ZD 850	806 314 199... ..	64
ZR 850	806 314 199... ..	63
852	806 104 161... ..	58
854R	806 104 172... ..	57
855L	806 104 197... ..	57
858	806 104 165... ..	58
859	806 104 166... ..	58
859L	806 104 167... ..	58
860	806 104 245... ..	59

Form Shape	ISO Nr. ohne Ø ISO no. without Ø	Seite Page
862	806 104 249... ..	59
ZD 862	806 314 249... ..	64
ZR 862	806 314 249... ..	63
863	806 104 250... ..	59
ZD 863	806 104 250... ..	65
867	806 104 496... ..	60
879	806 104 290... ..	60
880	806 104 140... ..	60
ZD 880	806 314 140... ..	64
ZR 880	806 314 140... ..	63
881	806 104 141... ..	60
ZD 889	806 314 540... ..	64
890	806 104 271... ..	61
892	806 104 299... ..	61
909	806 104 068... ..	53
9120	806 104 340... ..	66
9120Z	806 104 365... ..	70
9130	806 104 355... ..	69
9131	806 104 356... ..	69
ZD 9131	806 104 xxx... ..	65
9132	806 104 357... ..	69
9220	806 104 345... ..	67
9220P	806 104 350... ..	68
9221	806 104 346... ..	67
9221P	806 104 351... ..	68
9222	806 104 347... ..	67
9222P	806 104 352... ..	68
9340	806 104 355... ..	70
9460	806 104 405... ..	71
9470	806 104 605... ..	71
9500ZP	806 104 333... ..	70
9800	806 104 361... ..	71
9800Z	806 104 325... ..	71

© Swiss Precision Instruments AG
Schweiz

Alle Rechte sind der Swiss Precision Instruments
AG, Altstätten, vorbehalten.

Abbildungen und Fotos sind urheberrechtlich
geschützt. Nachdruck oder Reproduktionen in
irgendwelcher Form, auch auszugsweise, sind
nur mit schriftlicher Genehmigung der Swiss
Precision Instruments AG, Altstätten,
gestattet. Titel: ©benik.at – Fotolia.com

Für Druckfehler keine Haftung.

© Swiss Precision Instruments AG
Switzerland

All rights are reserved by Swiss Precision
Instruments AG, Altstätten.

Illustrations and photos are protected by
copyright. Reproductions, also by extract
in any form, are only permitted with written
authorization of Swiss Precision Instruments
AG, Altstätten. Title: ©benik.at – Fotolia.com

Not liable for misprints.

sw/ssdental

Swiss Precision Instruments AG

Tiefenackerstrasse 49

9450 Altstätten

Switzerland

T +41 (0)7 1556 7788

F +41 (0)7 1556 7780

info@swissdental.net

www.swissdental.net